

# RLS 310-410-510-610 Series

Modulating Dual Fuel Burners

Product Overview

## Overview

The high power monoblock Dual Fuel Burners Series, are the result of intensive activities of technical research and considerable investment, carried out in recent years, that allowed the highest levels of technological development to be achieved in the Industrial Burners context, confirming the historical leadership of Riello in this important area of energy management.

The remarkable results of performance, quality and reliability, are now consolidated by the creation of new models in the 3-6 MW range, RLS 310-410-510-610, able to summarize and concentrate the best technological expertise of Riello.

The new models RLS 310-410-510-610 characterized by technology, power and design, are authentic 'little giants' in the burners scenario; little in size and weight, giants in performance provided and in capability to meet the market needs.

These new models are available in various air-fuel ratio control configurations; Modulating Operation can be managed through Mechanical Cam for a simple commissioning and through Electronic Cam for higher performance and efficiency.

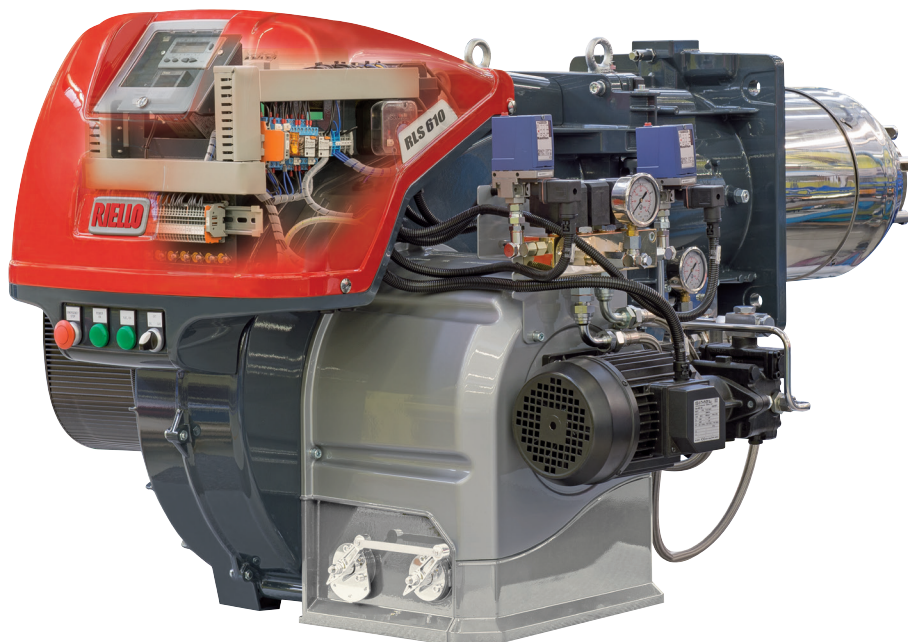

## Burner Models

EMISSIONS	MODELS	OPERATION (*)	
		/M	/E
Class 3 EN 676 Gas Class 2 EN 267 Oil	RLS 310 MX	•	•
	RLS 410 MX	•	•
	RLS 510 MX	•	•
	RLS 610 MX	•	•

(\*) /M = Two stage progressive - Modulating mechanical cam  
 /E = Two stage progressive - Modulating electronic cam

Modulating electronic cam models with Variable Speed Drive technology are available on demand.

MODELS	FIRING RATES - (kW)
RLS 310	600/1200 ÷ 3600
RLS 410	640/1500 ÷ 4200
RLS 510	680/1800 ÷ 5170
RLS 610	1000/2200 ÷ 6155

## Technical Data

### MECHANICAL CAM VERSIONS

MODEL		RLS 310/M MX	RLS 410/M MX	RLS 510/M MX	RLS 610/M MX
Burner operation mode		Modulating			
Modulation ratio at max. output		5 ÷ 1			
Servomotor		type SQM 40			
Heat output		kW		600/1200 ÷ 3600	640/1500 ÷ 4200
		Kg/h		50/100 ÷ 305	55/126 ÷ 352
Working temperature		°C min./max.		0/50	
<b>FUEL/AIR DATA</b>					
Light oil		net calorific value		kWh/kg	
		viscosity at 20°C		mm <sup>2</sup> /s (cSt)	
Pump		type		TA3	TA4
		output at 16.5 bar		kg/h	700
Pressure range		bar		7 ÷ 40	7 ÷ 30
Fuel temperature		max. °C		140	
Nozzle		Number		1	
G20 gas		net calorific value		kWh/Nm <sup>3</sup>	
		gas density		kg/Nm <sup>3</sup>	
G25 gas		net calorific value		kWh/Nm <sup>3</sup>	
		gas density		kg/Nm <sup>3</sup>	
Fan		type		Forward curve blades	
Combustion air temperature		max °C		60	
<b>ELECTRICAL DATA</b>					
Start up		type		Direct	
Electrical supply		Ph/ V/Hz		3N ~ 230V ±10% 50 Hz	
Total electrical power		kW Max		9.1 (gas)/ 10.9 (oil)	10.6 (gas)/ 12.4 (oli)
Fan motor		electrical power		kW	
		rated current		A	
		start up current		A	
		protection level		IP	
Start up		Type		Star - Delta	
Electrical supply		Ph/ V/Hz		3N ~ 400V ±10% 50 Hz	
Total electrical power		kW Max		8.8 (gas)/ 10.6 (oil)	10.6 (gas)/ 12.4 (oli)
Fan motor		electrical power		kW	
		rated current		A	
		start up current		A	
		protection level		IP	
Pump motor		electrical power		kW	
		rated current		A	
		start up current		A	
		protection level		IP	
Ignition transformer		V1 - V2		230V - 2 x 5 kV	
		I1 - I2		1.9 A - 35 mA	
Control box		type		LFL 1.333	
Motor protection level		IP		54	
Operation		Intermittent (at least one stop every 24 hours)			



**MECHANICAL CAM VERSIONS**

MODEL			RLS 310/M MX	RLS 410/M MX	RLS 510/M MX	RLS 610/M MX
<b>EMISSIONS</b>						
Noise levels	sound pressure	dB (A)	78	80	82.5	85
	sound power	W	89	91	93.5	96
Light oil	CO emission	mg/kWh	< 10			
	NOx emission	mg/kWh	< 185			
Gas G20	CO emission	mg/kWh	< 10			
	NOx emission	mg/kWh	< 80			
<b>APPROVAL</b>						
Directive			2006/42 - 2009/142 - 2004/108 - 2006/95 EC			
Conforming to			EN 267 - EN 676			
Certification			CE-0085CQ0196			

**Reference conditions:**

Temperature: 20°C - Pressure: 1013,5 mbar - Altitude: 0 m a.s.l. - Noise measured at a distance of 1 meter.

Since the Company is constantly engaged in the production improvement, the aesthetic and dimensional features, the technical data, the equipment and the accessories can be changed. This document contains confidential and proprietary information of RIELLO S.p.A. Unless authorised, this information shall not be divulged, nor duplicated in whole or in part.

**ELECTRONIC CAM VERSIONS**

MODEL		RLS 310/E MX	RLS 410/E MX	RLS 510/E MX	RLS 610/E MX
Burner operation mode		Modulating			
Modulation ratio at max. output		5 ÷ 1			
Servomotor		type SQM 33			
Heat output		kW 600/1200÷3600 640/1500 ÷4200 660/1800÷5170 1000/2200÷6155			
		Kg/h 50/100÷305 55/126÷352 56/195÷435 110/185÷516			
Working temperature		°C min./ max. 0/50			
<b>FUEL/AIR DATA</b>					
Light oil	net calorific value	kWh/kg		11.86	
	viscosity at 20°C	mm <sup>2</sup> /s (cSt)		4 ÷ 6	
Pump	type	TA3	TA4	TA5	
	output at 16.5 bar	kg/h 700	930	1270	
Pressure range		bar 7 ÷ 40		7 ÷ 30	
Fuel temperature		max. °C		140	
Nozzle	Number			1	
G20 gas	net calorific value	kWh/Nm <sup>3</sup>		10	
	gas density	kg/Nm <sup>3</sup>		0.71	
G25 gas	net calorific value	kWh/Nm <sup>3</sup>		8.6	
	gas density	kg/Nm <sup>3</sup>		0.78	
Fan		type Forward curve blades			
Combustion air temperature		max °C		60	
<b>ELECTRICAL DATA</b>					
Start up		type Direct			
Electrical supply		Ph/ V/Hz 3N ~ 230V ±10% 50 Hz			
Total electrical power		kW Max 9.1 (gas)/ 10.9 (oil)		10.6 (gas)/ 12.4 (oli)	
Fan motor	electrical power	kW 7.5		9.2	
	rated current	A 24 - 14		28.6 - 16.5	
	start up current	A			
	protection level	IP 54			
Start up		Type Star - Delta			
Electrical supply		Ph/ V/Hz 3N ~ 400V ±10% 50 Hz			
Total electrical power		kW Max 8.8 (gas)/ 10.6 (oil)		10.6 (gas)/ 12.4 (oli)	
		13.9 (gas)/ 15.7 (oil)		16.9 (gas)/ 18.7 (oil)	
Fan motor	electrical power	kW 7.5		9.2	
	rated current	A 14 - 8.1		21.8 - 12.6	
	start up current	A			
	protection level	IP 54			
Pump motor	electrical power	kW 1.5			
	rated current	A 5.9/3.4			
	start up current	A 7 x I <sub>n</sub>			
	protection level	IP 54			
Ignition transformer	V1 - V2	230V - 2 x 5 kV			
	I1 - I2	1.9 A - 35 mA			
Control box		type LMV 26			
Motor protection level		IP 54			
Operation		Intermittent (at least one stop every 24 hours)			

**ELECTRONIC CAM VERSIONS**

MODEL		RLS 310/E MX	RLS 410/E MX	RLS 510/E MX	RLS 610/E MX	
<b>EMISSIONS</b>						
Noise levels	sound pressure	dB (A)	78	80	82.5	85
	sound power	W	89	91	93.5	96
Light oil	CO emission	mg/kWh			< 10	
	NOx emission	mg/kWh			< 185	
Gas G20	CO emission	mg/kWh			< 10	
	NOx emission	mg/kWh			< 80	
<b>APPROVAL</b>						
Directive			2006/42 - 2009/142 - 2004/108 - 2006/95 EC			
Conforming to			EN 267 - EN 676			
Certification			CE-0085CQ0196			

**Reference conditions:**

Temperature: 20°C - Pressure: 1013,5 mbar - Altitude: 0 m a.s.l. - Noise measured at a distance of 1 meter.

Since the Company is constantly engaged in the production improvement, the aesthetic and dimensional features, the technical data, the equipment and the accessories can be changed. This document contains confidential and proprietary information of RIELLO S.p.A. Unless authorised, this information shall not be divulged, nor duplicated in whole or in part.

# Firing Rates

RLS 310-410-510-610/M - /E MX

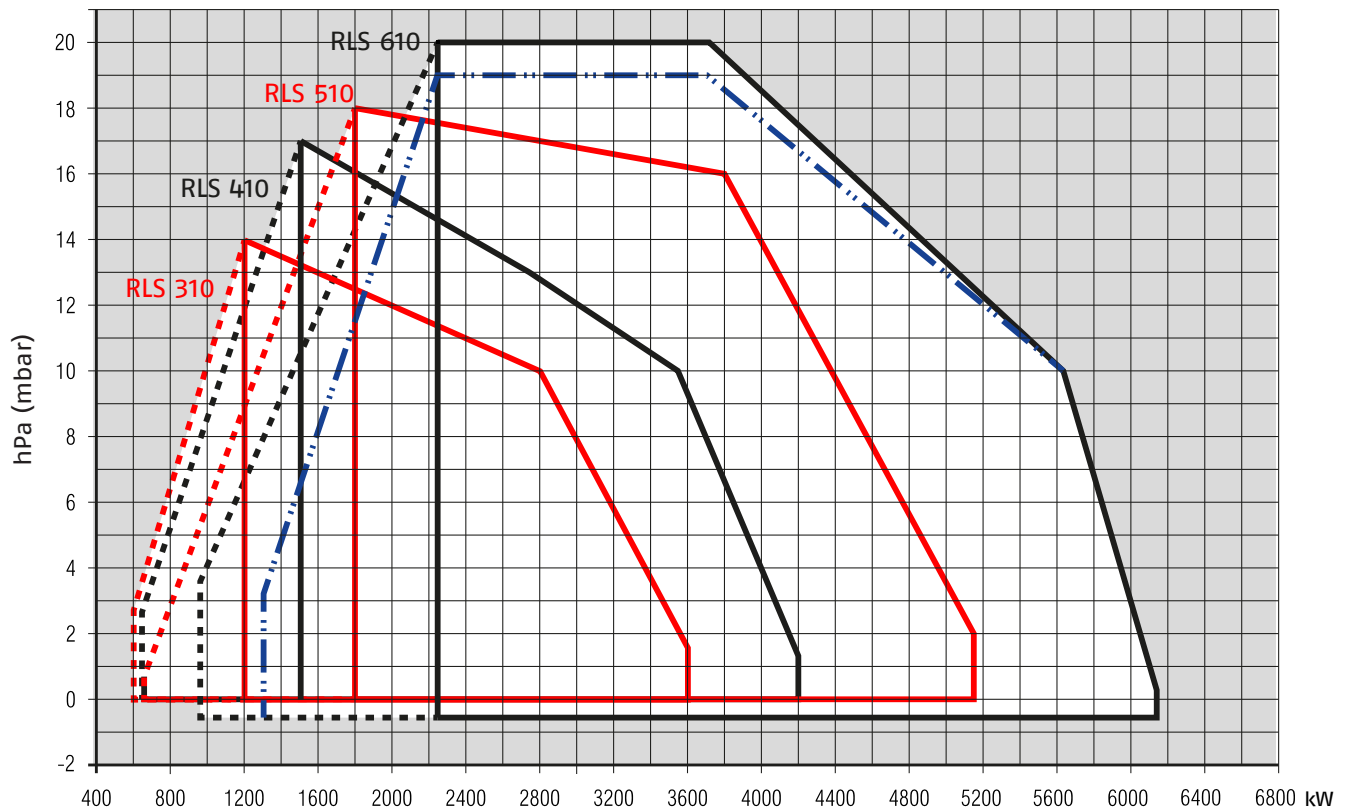

Useful working field  
for choosing the  
burner



Modulation range

Test conditions  
conforming to EN267- EN676  
Temperature: 20°C  
Pressure: 1013,5 mbar  
Altitude: 0 m a.s.l.



Light-oil  
firing rate  
for RLS 610 model  
(min. output 1.300 kW)



**GAS TRAIN DESIGNATION**

Series: MB

MBC
DMV
DMV12
VGD
CB
CBH
MV
CG

Size:	405	407	410	412	415	420							
		65	120	300	700	1200	-	1900	3100	5000			
	505	507	510	512	-	520	525	5065	5080	50100	50125	50150	
	10	15	20	32	40	-	50	-	65	80	100	125	150
		120	220										

Operation:

/S	only ON-OFF function
/1	stage mode opening
/2	2nd stage mode opening
/P	1st stage mode opening with air/gas proportional regulator

Leak detection control:

-	0
CT	leak detection control device installed on the gas train
CQ	equipped with pressure switch for leak detection control

Joint type:

R	threaded joint
F	standard flange ISO
F1	square flange BS1
F2	square flange BS2
F3	square flange BS3 - BS4

Electrical connection:

T	Terminals - Terminal strip
SD	Domestic plug
SM	Medium voltage plug

Standard output pressure range:

-	without pressure governor
0	with governor and air/gas proportional pressure
2	with governor and output pressure up to 20 mbar
3	with governor and output pressure up to 30 mbar
4	with governor and output pressure up to 40 mbar
5	with governor and output pressure up to 50 mbar
6	with governor and output pressure up to 60 mbar
8	with governor and output pressure up to 80 mbar
15	with governor and output pressure up to 150 mbar

Valve control:

0	shared
2	separate

CB	5065	/1	CT	F	SM	3	0
BASIC DESIGNATION			EXTENDED DESIGNATION				

**GAS TRAINS**

The burners are fitted with a butterfly valve to regulate the fuel, controlled by the main management module of burner through a high precision servomotor.  
 Fuel can be supplied either from the right or left sides, on the basis of the application requirements.  
 A maximum gas pressure switch stops the burner in case of excess pressure in the fuel line.  
 The gas train can be selected to best fit system requirements depending on the fuel output and pressure in the supply line.  
 The gas trains are with or without seal control.

**MB "THREADED"**

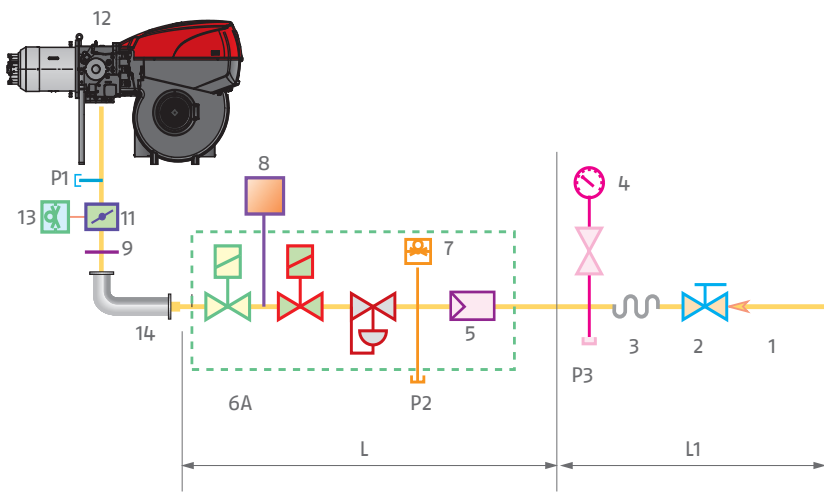

- 1 Gas input pipework
- 2 Manual valve
- 3 Anti-vibration joint
- 4 Pressure gauge with pushbutton cock
- 5 Filter
- 6A Includes:
  - filter
  - operation valve
  - safety valve
  - pressure adjuster
- 7 Minimum gas pressure switch
- 8 Leak detection device, supplied as an accessory or incorporated, based on the gas train code.
- 9 Gasket, for "flanged" versions only
- 10 Pressure adjuster
- 11 Gas adjuster butterfly valve
- 12 Burner
- 13 Maximum gas pressure switch
- 14 Gas train-burner adaptor, supplied separately
- P1 Combustion head pressure
- P2 Upstream pressure of valves
- P3 Upstream pressure of the filter
- L Gas train supplied separately, with the code given in the table.
- L1 Installer's responsibility

**MBC "THREADED"**

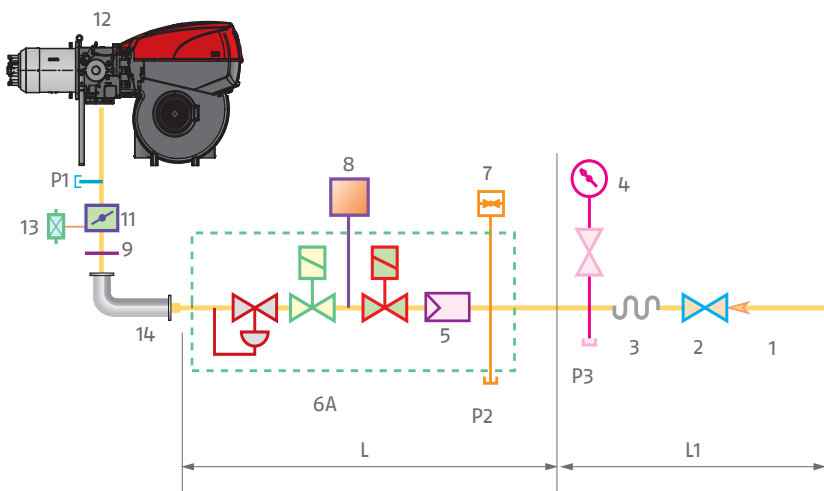

**MBC "FLANGED"**

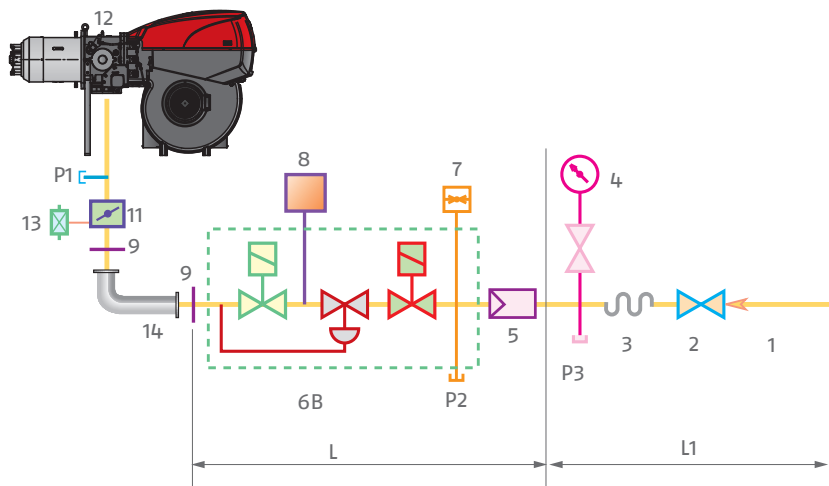

- 1 Gas input pipework
- 2 Manual valve
- 3 Anti-vibration joint
- 4 Pressure gauge with pushbutton cock
- 5 Filter
- 6B Includes:
  - operation valve
  - safety valve
  - pressure adjuster
- 6C Includes:
  - operation valve
  - safety valve
- 6D Includes:
  - operation valve
  - safety valve
- 7 Minimum gas pressure switch
- 8 Leak detection device, supplied as an accessory or incorporated, based on the gas train code.

- 9 Gasket, for "flanged" versions only
- 10 Pressure adjuster
- 11 Gas adjuster butterfly valve
- 12 Burner
- 13 Maximum gas pressure switch
- 14 Gas train-burner adaptor, supplied separately
- P1 Combustion head pressure
- P2 Upstream pressure of valves
- P3 Upstream pressure of the filter
- L Gas train supplied separately, with the code given in the table

L1 Installer's responsibility

**CB "FLANGED OR THREADED"**

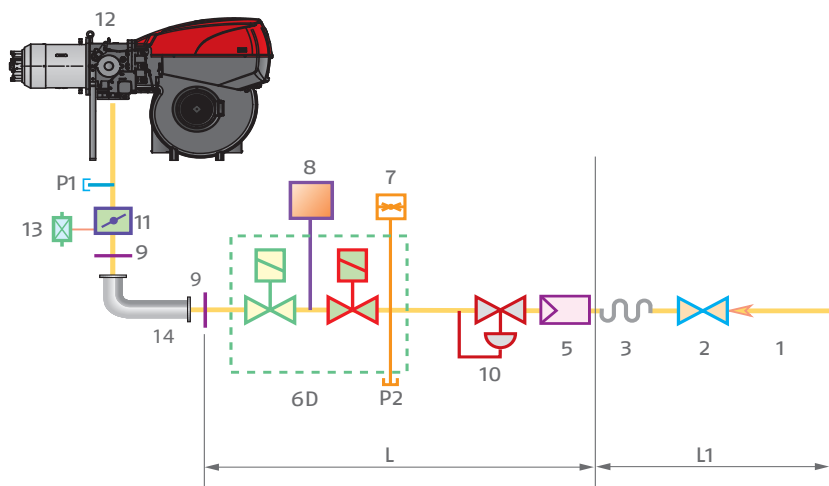

**DMV "FLANGED OR THREADED"**

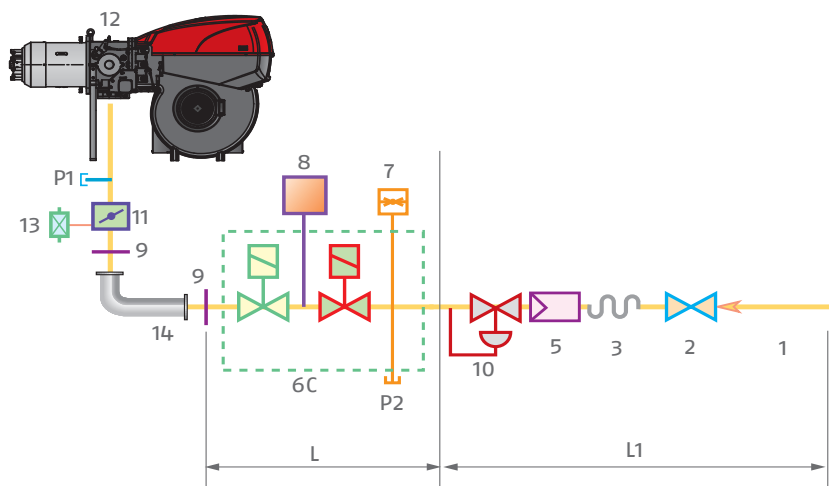

Gas trains are approved by standard EN 676 together with the burner.

The overall dimensions of the gas train depends on how they are constructed. The following table shows the maximum dimensions of the gas trains that can be fitted to RS 650-800-1000-1200/M BLU burners, intake and outlet diameters and seal control if fitted.

The maximum gas pressure of gas train "MULTIBLOC" type is 360 mbar, and that one of gas train "COMPOSED" type is 500 mbar.

"MULTIBLOC" guarantees a range of pressure towards the burner from 4 to 60 mbar. For version DN 65 and DN 80 is from 20 to 40 mbar. For version DN 100 is from 40 to 80 mbar. The range of pressure in the "MULTIBLOC" with flange can be modified choosing the stabiliser spring (see gas train accessory).

The maximum gas pressure of gas train "CB" series is 500 mbar. "CB" gas train guarantees a range of pressure towards the burner from 10 to 30 mbar. The range of pressure can be modified choosing the stabilizer spring (see accessories).

The maximum gas pressure of gas train "DMV" series is 500 mbar. "DMV" gas train is supplied without pressure governor.

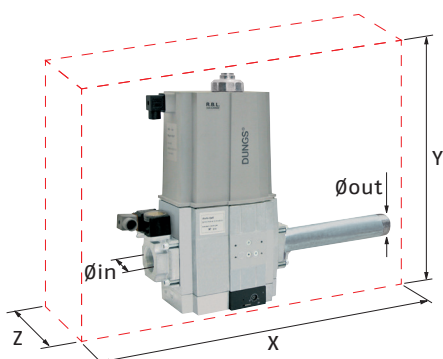

Example of gas train "MULTIBLOC" type without seal control (i.e. MBC 1200)

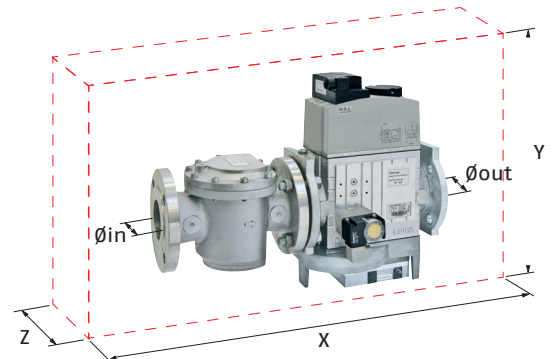

Example of gas train "COMPOSED" type without seal control (i.e. MBC 1900-3100-5000)

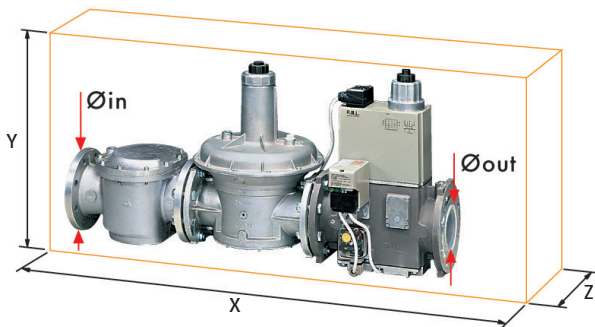

Example of gas train "CB" series with seal control

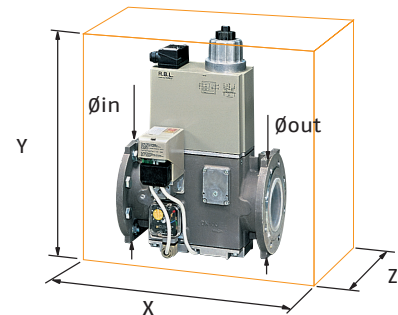

Example of gas train "DMV" series with seal control

**GAS TRAIN**

MODEL	CODE	Ø in	Ø out	X mm	Y mm	Z mm
MB 415/1 - RT 30	3970180	Rp 1-1/2"	Rp 1-1/2"	523	250	100
MB 415/1 CT RT 30	3970198	Rp 1-1/2"	Rp 1-1/2"	523	250	229
MB 415/1 - RT 52	3970250	Rp 1-1/2"	Rp 1-1/2"	523	250	100
MB 415/1 CT RT 52	3970253	Rp 1-1/2"	Rp 1-1/2"	523	250	229
MB 415/1 RSM 30	3970232	Rp 1-1/2"	Rp 1-1/2"	523	250	100
MB 420/1 RT 30	3970181	Rp 2"	Rp 2"	523	289	100
MB 420/1 CT RT 30	3970182	Rp 2"	Rp 2"	523	289	229
MB 420/1 RT 52	3970257	Rp 2"	Rp 2"	523	289	100
MB 420/1 CT RT 52	3970252	Rp 2"	Rp 2"	523	289	229
MB 420/1 RSM 30	3970233	Rp 2"	Rp 2"	523	289	100
MB 420/1 CT RSM 30	3970234	Rp 2"	Rp 2"	523	289	229



<b>GAS TRAIN</b>						
<b>MODEL</b>	<b>CODE</b>	<b>∅ in</b>	<b>∅ out</b>	<b>X mm</b>	<b>Y mm</b>	<b>Z mm</b>
MBC 1200/1 - RSM 60	3970221	Rp 2"	Rp 2"	528	424	161
MBC 1200/1 CT RSM 60	3970225	Rp 2"	Rp 2"	528	424	290
MBC 1900/1 - FSM 40	3970222	DN 65	DN 65	613	430	237
MBC 1900/1 CT FSM 40	3970226	DN 65	DN 65	613	430	298
MBC 3100/1 - FSM 40	3970223	DN 80	DN 80	633	500	240
MBC 3100/1 CT FSM 40	3970227	DN 80	DN 80	633	500	319
MBC 5000/1 - FSM 80	3970224	DN 100	DN 100	733	576	280
MBC 5000/1 CT FSM 80	3970228	DN 100	DN 100	733	576	348

<b>GAS TRAIN</b>						
<b>MODEL</b>	<b>CODE</b>	<b>∅ in</b>	<b>∅ out</b>	<b>X mm</b>	<b>Y mm</b>	<b>Z mm</b>
CB 512/1 - RSM 30	3970145	Rp 1-1/2"	Rp 1-1/2"	891	261	245
CB 512/1 - CT RSM 30	20045589	Rp 1-1/2"	Rp 1-1/2"	891	261	245
CB 520/1 - RSM 30	3970146	Rp 2"	Rp 2"	986	328	255
CB 520/1 - CT RSM 30	3970160	Rp 2"	Rp 2"	986	328	255
CB 525/1 - RSM 30	20044659	Rp 2"	Rp 2"	1025	356	285
CB 525/1 - CT RSM 30	20044660	Rp 2"	Rp 2"	1025	356	285
CB 5065/1 - FSM 30	3970147	DN 65	DN 65	906	356	285
CB 5065/1 CT FSM 30	3970161	DN 65	DN 65	906	356	285
CB 5080/1 - FSM 30	3970148	DN 80	DN 80	934	416	285
CB 5080/1 CT FSM 30	3970162	DN 80	DN 80	934	416	285
CB 50100/1 - FSM 30	3970149	DN 100	DN 100	1054	501	350
CB 50100/1 CT FSM 30	3970163	DN 100	DN 100	1054	501	350
CB 50125/1 - FSM 30	20015871	DN 125	DN 125	1164	780	400
CB 50125/1 CT FSM 30	3970196	DN 125	DN 125	1164	780	400

<b>GAS TRAIN</b>						
<b>MODEL</b>	<b>CODE</b>	<b>∅ in</b>	<b>∅ out</b>	<b>X mm</b>	<b>Y mm</b>	<b>Z mm</b>
DMV 512/1 - RSM - 0	20043035	Rp 1-1/2"	Rp 1-1/2"	490	292	245
DMV 512/1 -CT RSM - 0	20043036	Rp 1-1/2"	Rp 1-1/2"	490	292	245
DMV 512/1 - CQ RSM - 2	20043037	Rp 1-1/2"	Rp 1-1/2"	490	292	245
DMV 520/1 - RSM - 0	20043038	Rp 2"	Rp 2"	490	292	255
DMV 520/1 CT RSM - 0	20043039	Rp 2"	Rp 2"	490	292	255
DMV 520/1 CQ RSM - 2	20043040	Rp 2"	Rp 2"	490	292	255
DMV 525/1 - RSM - 0	20043053	Rp 2"	Rp 2"	530	338	270
DMV 525/1 CT RSM - 0	20043054	Rp 2"	Rp 2"	530	338	270
DMV 525/1 CQ RSM - 2	20043055	Rp 2"	Rp 2"	530	338	270
DMV 5065/1 - FSM - 0	20043041	DN 65	DN 65	290	338	270
DMV 5065/1 CT FSM - 0	20043042	DN 65	DN 65	290	338	270
DMV 5065/1 CQ FSM - 2	20043043	DN 65	DN 65	290	338	270
DMV 5080/1 - FSM - 0	20043044	DN 80	DN 80	310	397	290
DMV 5080/1 CT FSM - 0	20043045	DN 80	DN 80	310	397	290
DMV 5080/1 CQ FSM - 2	20043046	DN 80	DN 80	310	397	290
DMV 50100/1 - FSM - 0	20043047	DN 100	DN 100	350	449	307
DMV 50100/1 CT FSM - 0	20043048	DN 100	DN 100	350	449	307
DMV 50100/1 CQ FSM - 2	20043049	DN 100	DN 100	350	449	307
DMV 50125/1 - FSM - 0	20043050	DN 125	DN 125	400	554	333
DMV 50125/1 CT FSM - 0	20043051	DN 125	DN 125	400	554	333
DMV 50125/1 CQ FSM - 2	20043052	DN 125	DN 125	400	554	333

# Pressure Drop Diagram

The diagrams indicate the minimum pressure drop of the burners with the various gas trains that can be matched with them; at the value of these pressure drop add the combustion chamber pressure. The value thus calculated represents the minimum required input pressure to the gas train.

The minimum input gas pressure required is 15 mbar while burner operating. In particular, the pressure difference between gas train upstream and downstream has to remain always over pressure drop values indicated below.

## RLS 310/M - /E MX MB

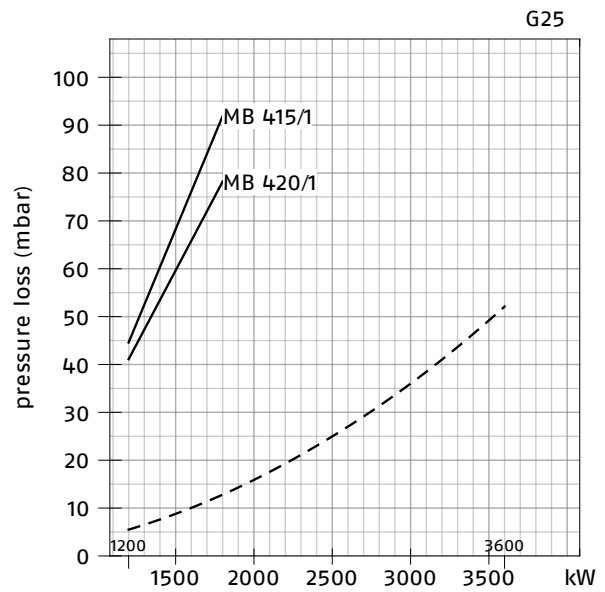
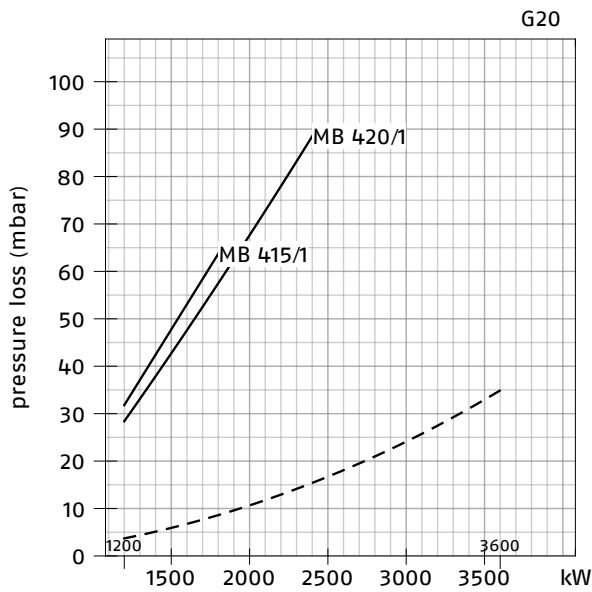

## RLS 310/M - /E MX MBC

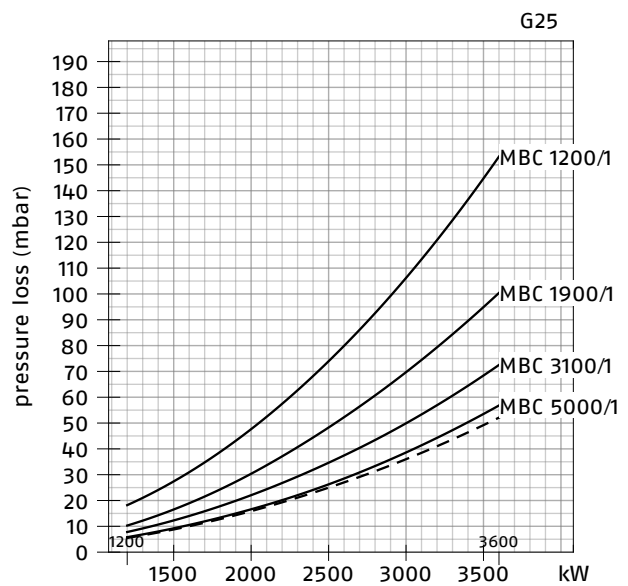
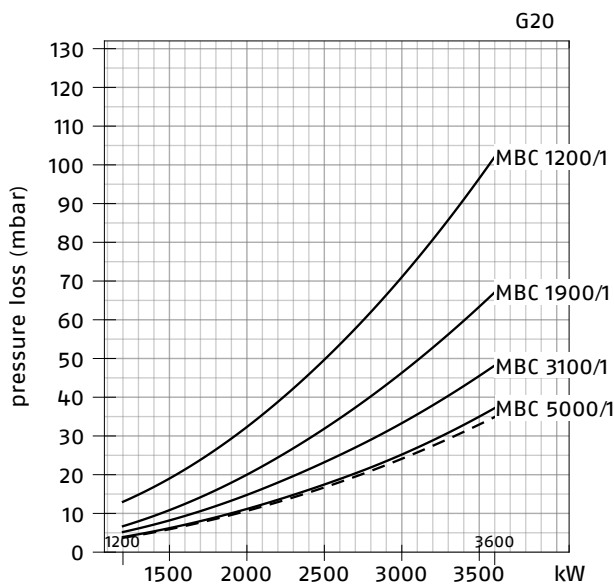

- Combustion head + gas butterfly valve + gas train
- - - Combustion head + gas butterfly valve

**RLS 310/M - /E MX CB**

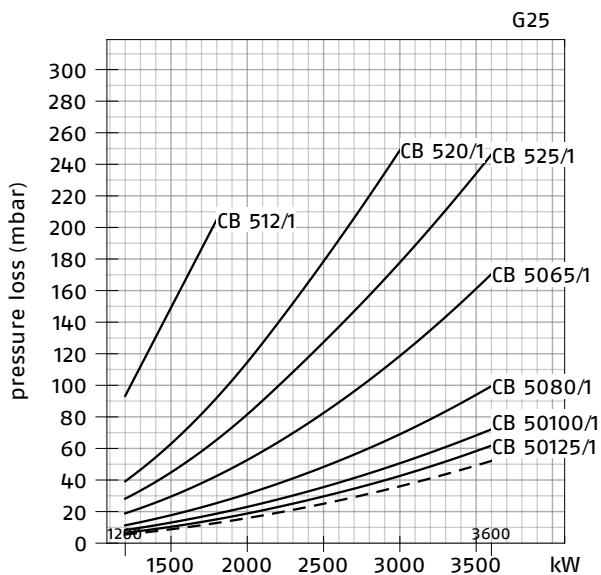
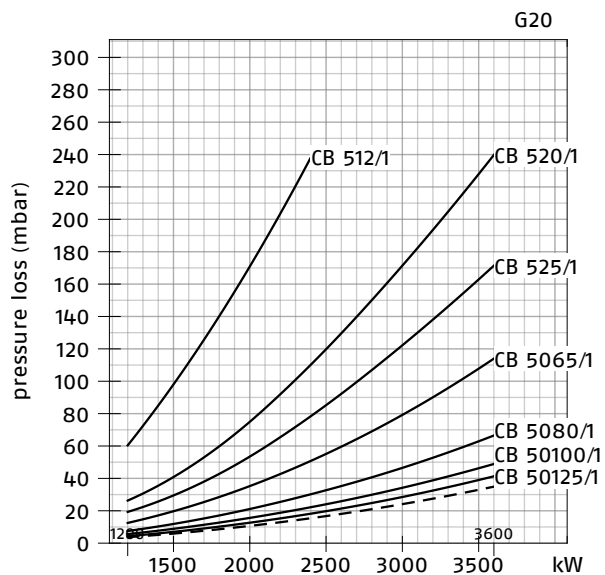

**RLS 310/M - /E MX DMV**

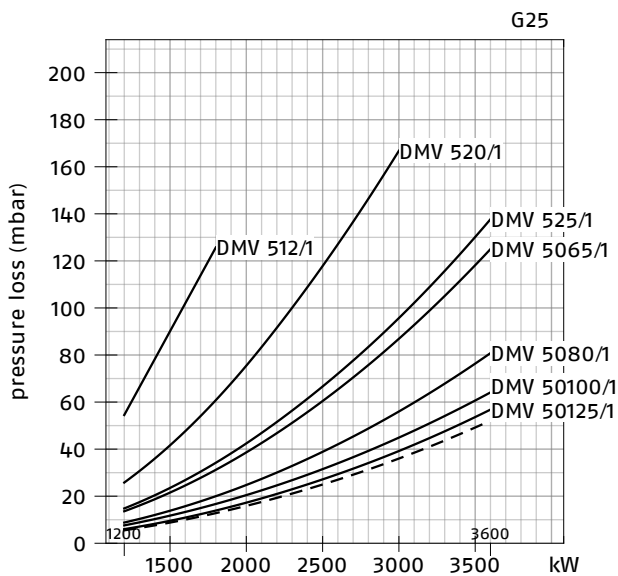
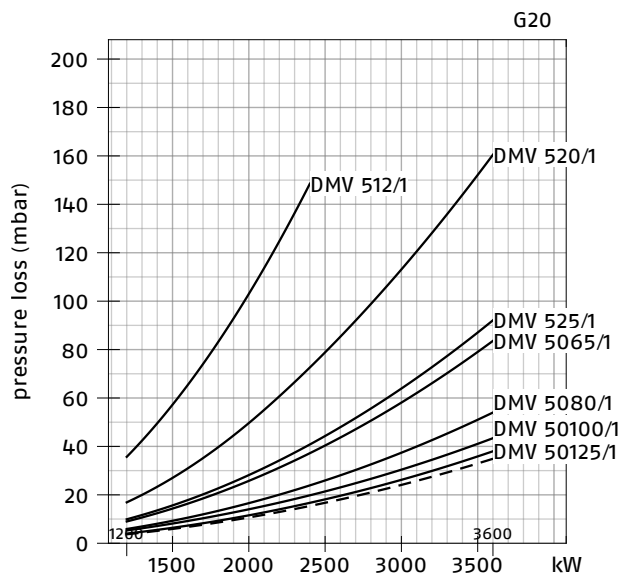

- Combustion head + gas butterfly valve + gas train
- - - Combustion head + gas butterfly valve

RLS 410/M - /E MX MBC

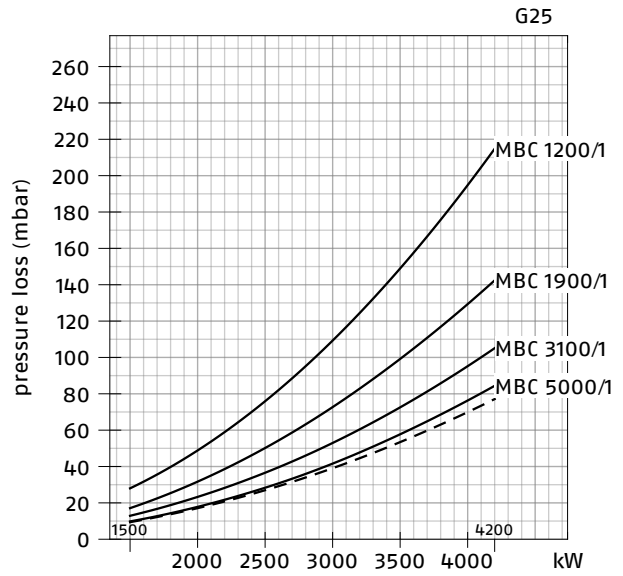
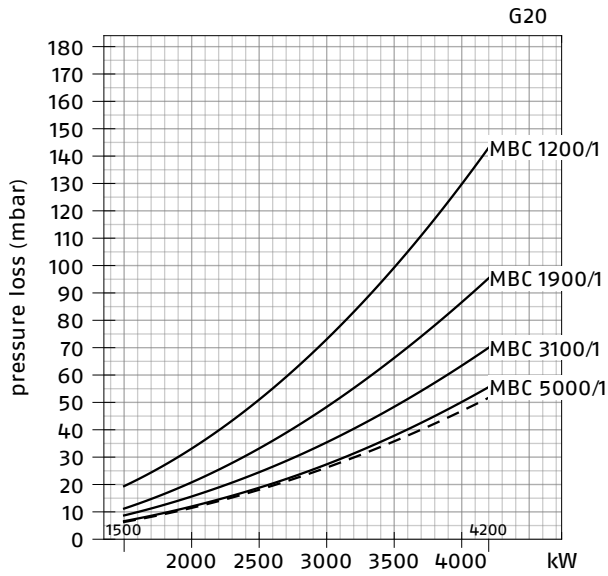

RLS 410/M - /E MX CB

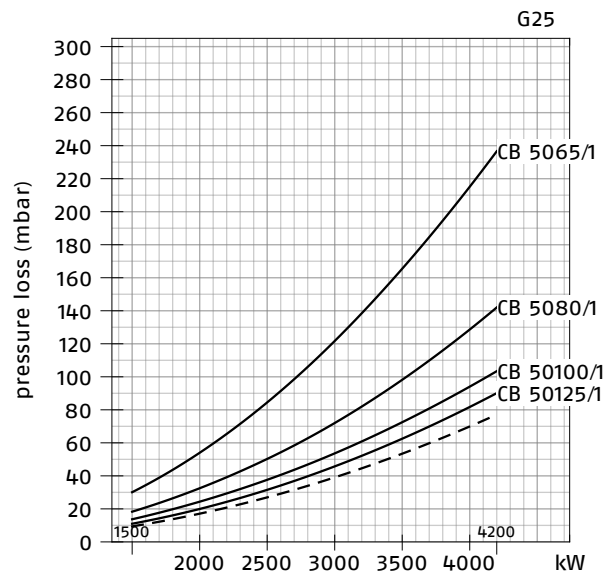
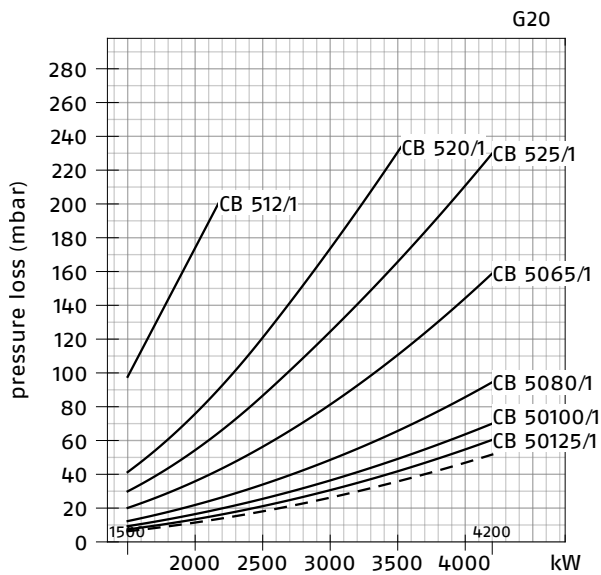

— Combustion head + gas butterfly valve + gas train  
 - - - Combustion head + gas butterfly valve



**RLS 410/M - /E MX DMV**

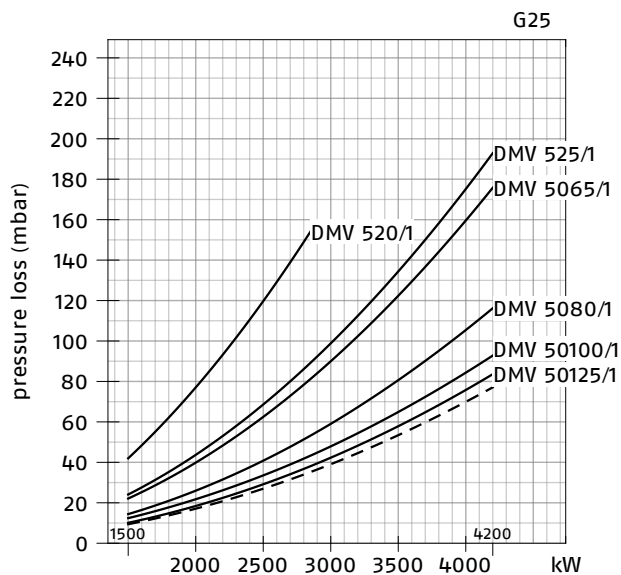
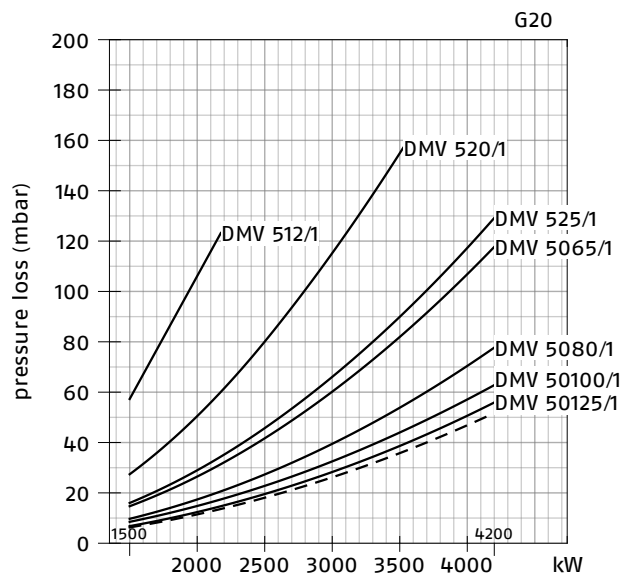

**RLS 510/M - /E MX MBC**

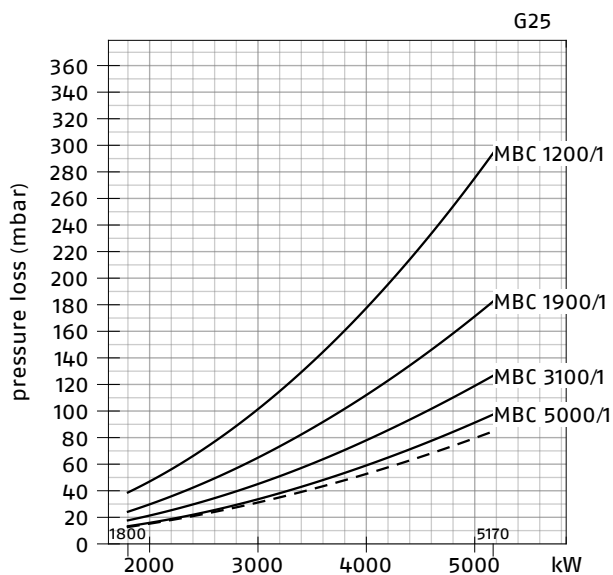
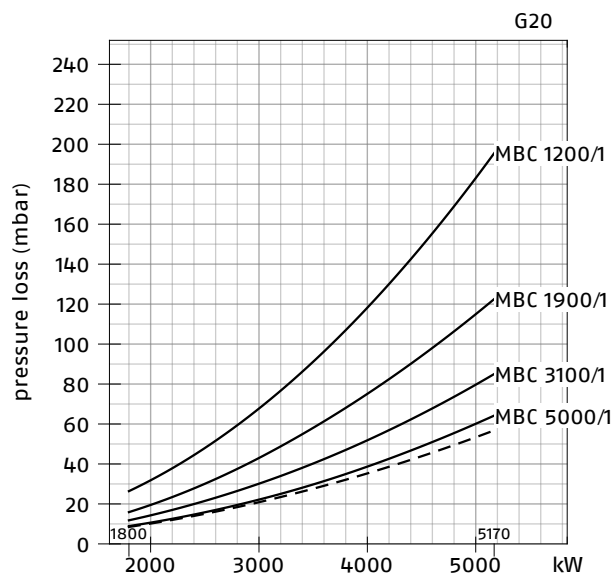

— Combustion head + gas butterfly valve + gas train  
 - - - Combustion head + gas butterfly valve

RLS 510/M - /E MX CB

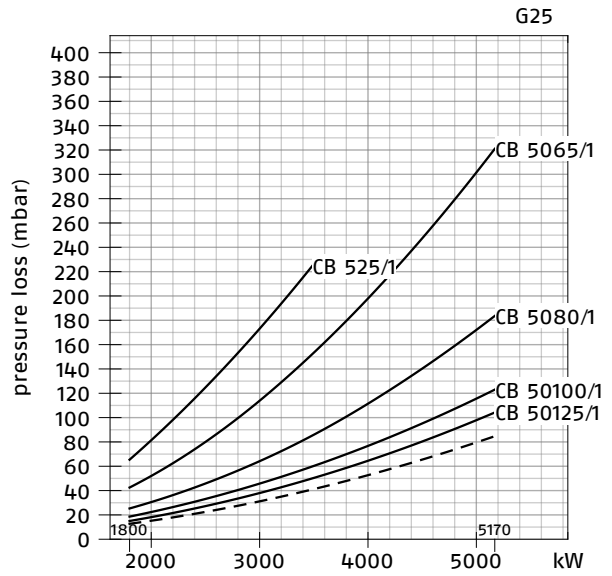
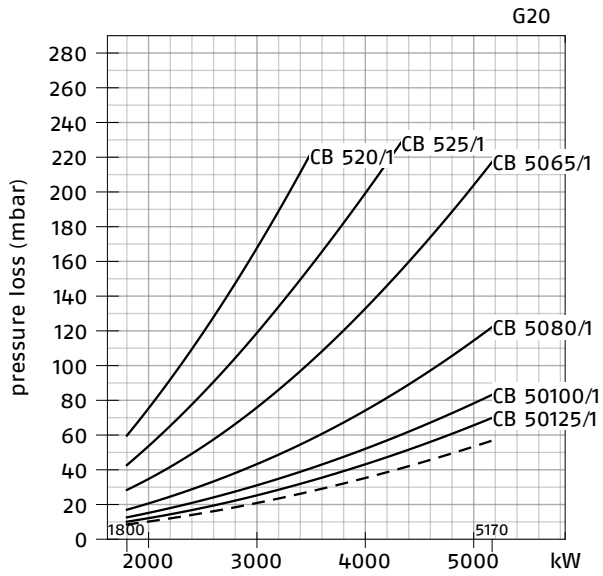

RLS 510/M - /E MX DMV

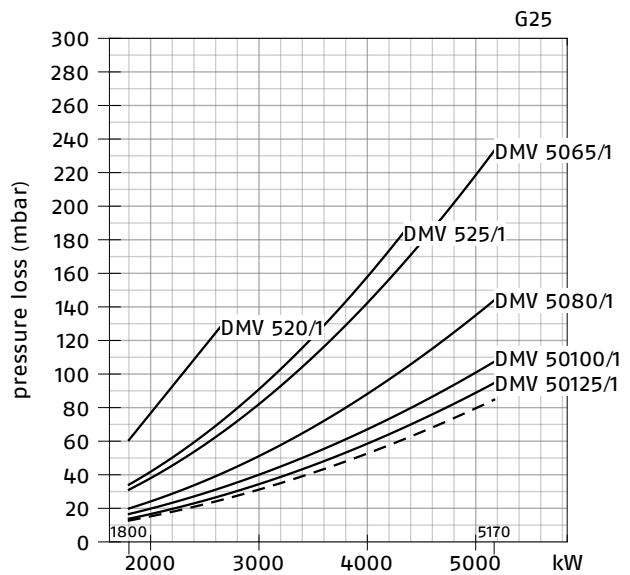
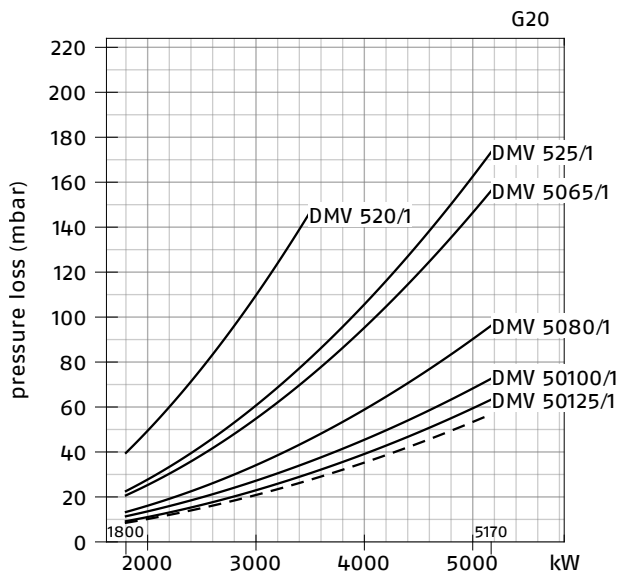

— Combustion head + gas butterfly valve + gas train  
 - - - Combustion head + gas butterfly valve

**RLS 610/M - /E MX MBC**

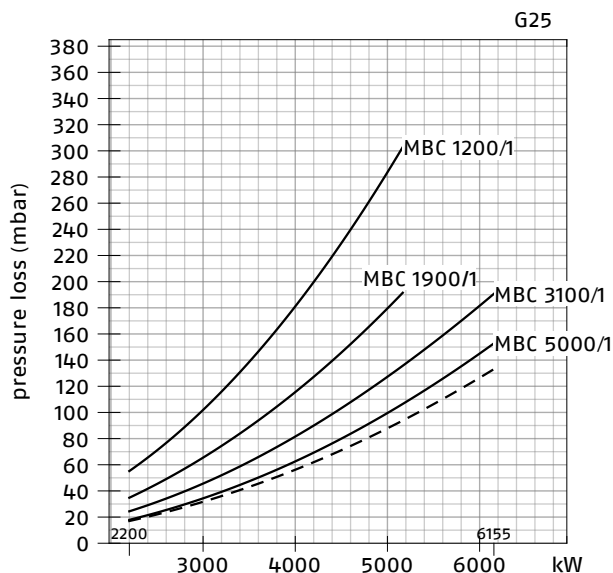
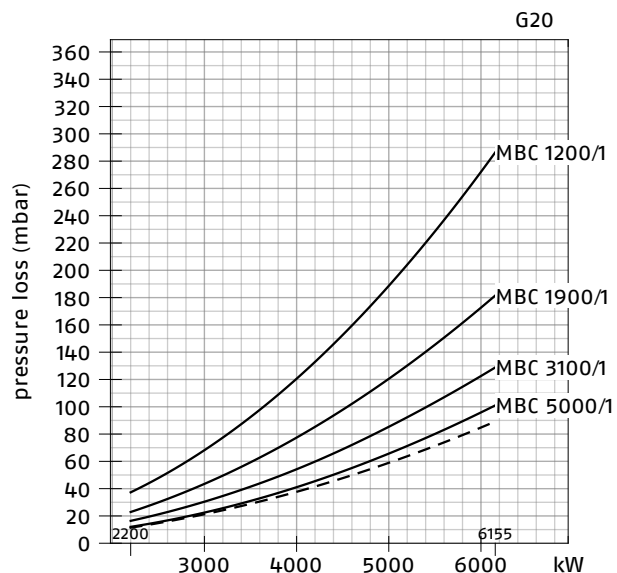

**RLS 610/M - /E MX CB**

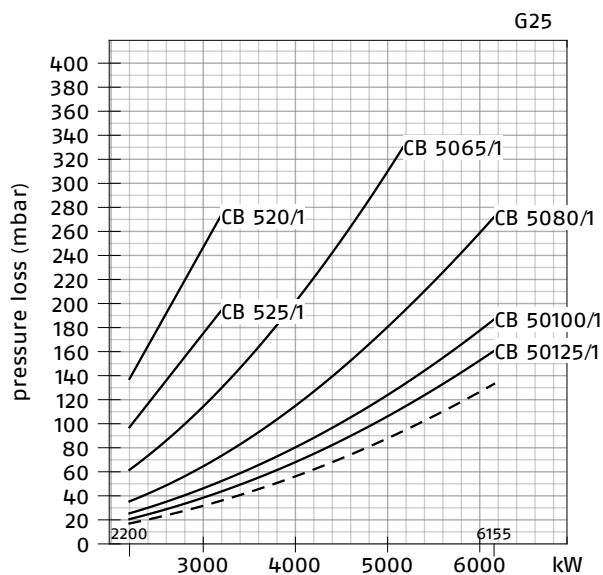
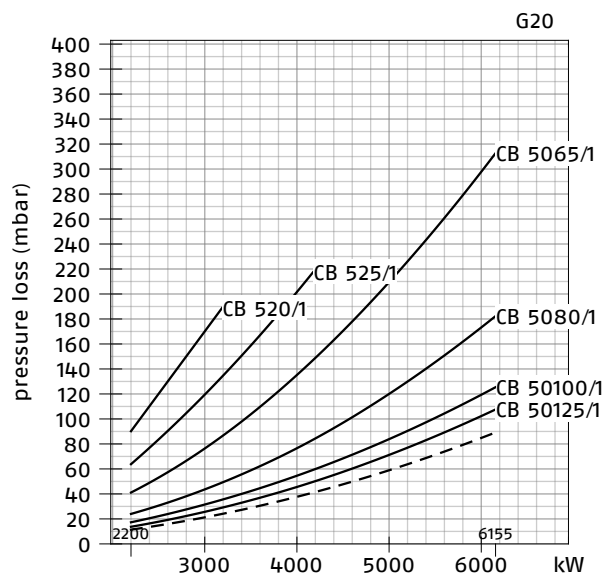

— Combustion head + gas butterfly valve + gas train  
 - - - Combustion head + gas butterfly valve

RLS 610/M - /E MX DMV

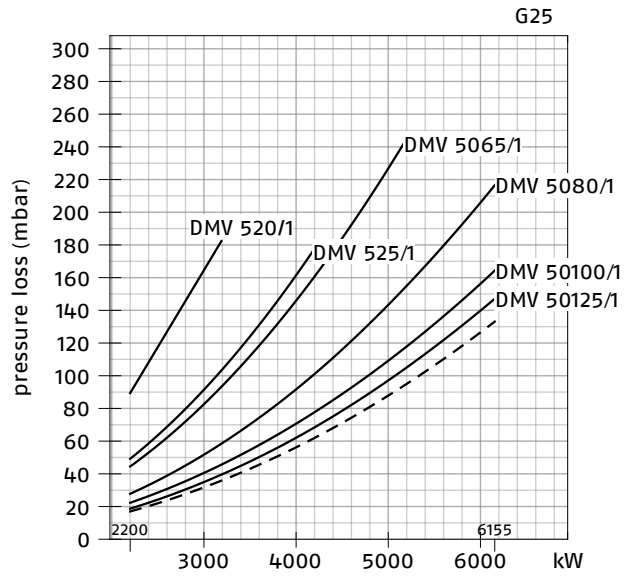
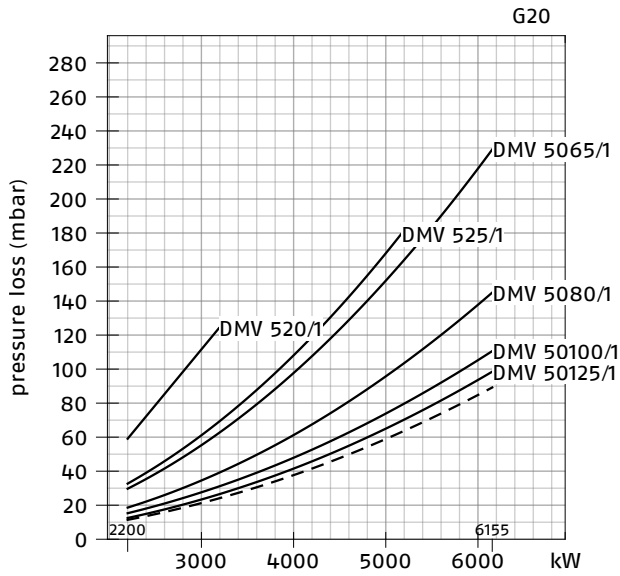

- Combustion head + gas butterfly valve + gas train
- - - Combustion head + gas butterfly valve

GAS TRAIN			VPS KIT	CQ KIT	ADAPTER			
CODE	MODEL	◆	CODE	CODE	CODE			
					RLS 310	RLS 410	RLS 510	RLS 610
3970180	MB 415/1 - RT 30	-	3010123	-	3000826 + 20064220	●	●	●
3970198	MB 415/1 CT RT 30	CT	-	-	3000826 + 20064220	●	●	●
3970250	MB 415/1 - RT 52	-	3010123	3010344	3000826 + 20064220	●	●	●
3970253	MB 415/1 CT RT 52	CT	-	-	3000826 + 20064220	●	●	●
3970232	MB 415/1 - RSM 30	-	3010123	-	3000826 + 20064220	●	●	●
3970181	MB 420/1 - RT 30	-	3010123	-	3000826 + 20042324	●	●	●
3970182	MB 420/1 CT RT 30	CT	-	-	3000826 + 20042324	●	●	●
3970257	MB 420/1 - RT 52	-	3010123	3010344	3000826 + 20042324	●	●	●
3970252	MB 420/1 CT RT 52	CT	-	-	3000826 + 20042324	●	●	●
3970233	MB 420/1 - RSM 30	-	3010123	-	3000826 + 20042324	●	●	●
3970234	MB 420/1 CT RSM 30	CT	-	-	3000826 + 20042324	●	●	●
3970221	MBC 1200/1 - RSM 60	-	3010367	3010344	3000826 + 20042324			
3970225	MBC 1200/1 CT RSM 60	CT	-	-	3000826 + 20042324			
3970222	MBC 1900/1 - FSM 40	-	3010367	3010344	3010221			
3970226	MBC 1900/1 CT FSM 40	CT	-	-	3010221			
3970223	MBC 3100/1 - FSM 40	-	3010367	3010344	3010222			
3970227	MBC 3100/1 CT FSM 40	CT	-	-	3010222			
3970224	MBC 5000/1 - FSM 80	-	3010367	3010344	3010223 - 3010370			
3970228	MBC 5000/1 CT FSM 80	CT	-	-	3010223 - 3010370			
3970145	CB 512/1 - RSM 30	-	3010367	3010344	3000826 + 20064220	●	●	●
20045589	CB 512/1 CT RSM 30	CT	-	-	3000826 + 20064220	●	●	●
3970146	CB 520/1 - RSM 30	-	3010367	3010344	3000826 + 20042324			●
3970160	CB 520/1 CT RSM 30	CT	-	-	3000826 + 20042324			●
20044659	CB 525/1 - RSM 30	-	3010367	3010344	3000826 + 20042324			
20044660	CB 525/1 CT RSM 30	CT	-	-	3000826 + 20042324			
3970147	CB 5065/1 - FSM 30	-	3010367	3010344	3010221			
3970161	CB 5065/1 CT FSM 30	CT	-	-	3010221			

GAS TRAIN			VPS KIT	CQ KIT	ADAPTER			
CODE	MODEL	◆	CODE	CODE	CODE			
					RLS 310	RLS 410	RLS 510	RLS 610
3970148	CB 5080/1 - FSM 30	-	3010367	3010344	3010222			
3970162	CB 5080/1 CT FSM 30	CT	-	-	3010222			
3970149	CB 50100/1 - FSM 30	-	3010367	3010344	3010223 - 3010370			
3970163	CB 50100/1 CT FSM 30	CT	-	-	3010223 - 3010370			
20015871	CB 50125/1 - FSM 30	-	3010367	3010367	3010224			
3970196	CB 50125/1 CT FSM 30	CT	-	-	3010224			
20043035	DMV 512/1 - RSM -0	-	3010367		3000826 - 20064220	●	●	
20043036	DMV 512/1 CT RSM -0	CT	-	-	3000826 - 20064220	●	●	
20043037	DMV 512/1 CQ RSM -2	CQ	-	-	3000826 - 20064220	●	●	
20043038	DMV 520/1 - RSM -0	-	3010367	3010344	3000826 - 20042324			●
20043039	DMV 520/1 CT RSM -0	CT	-	-	3000826 - 20042324			●
20043040	DMV 520/1 CQ RSM -2	CQ	-	-	3000826 - 20042324			●
20043053	DMV 525/1 - RSM -0	-	3010367	3010344	3000826 - 20042324			
20043054	DMV 525/1 CT RSM -0	CT	-	-	3000826 - 20042324			
20043055	DMV 525/1 CQ RSM -2	CQ	-	-	3000826 - 20042324			
20043041	DMV 5065/1 - FSM -0	-	3010367	3010344	3010221			
20043042	DMV 5065/1 CT FSM -0	CT	-	-	3010221			
20043043	DMV 5065/1 CQ FSM -2	CQ	-	-	3010221			
20043044	DMV 5080/1 - FSM -0	-	3010367	3010344	3010222			
20043045	DMV 5080/1 CT FSM -0	CT	-	-	3010222			
20043046	DMV 5080/1 CQ FSM -2	CQ	-	-	3010222			
20043047	DMV 50100/1 - FSM -0	-	3010367	3010344	3010223 - 3010370			
20043048	DMV 50100/1 CT FSM -0	CT	-	-	3010223 - 3010370			
20043049	DMV 50100/1 CQ FSM -2	CQ	-	-	3010223 - 3010370			
20043050	DMV 50125/1 - FSM -0	-	3010367	3010344	3010224			
20043051	DMV 50125/1 CT FSM -0	CT	-	-	3010224			
20043052	DMV 50125/1 CQ FSM -2	CQ	-	-	3010224			

- ◆ Gas valve leak detection control device:
  - gas train not equipped with leak detection control device; this device can be ordered separately - see VPS column - and installed later.
  - CT gas train equipped with VPS leak detection control device for burners /M.
  - CQ gas train with pressure switch for leak detection control of burners /E.
- VPS KIT Valve leak detection control device. Supplied separately from the gas train, on demand.
- CQ KIT Additional pressure switch for leak detection control in combination with burners /E.
- Gas train not available or not suitable for the matching to the burner.

## Hydraulic circuits

The hydraulic circuit of the RLS 310-410-510-610 series of burners is characterised by a fuel pump with an independent motor.

The burners are fitted with two valves (a safety valve and an operation valve) and an oil filter along the oil line from the pump to the nozzle.

A pressure regulator on the return circuit from the nozzle enables the quantity of fuel burnt to be varied. Two safety valves on the return circuit avoid oil leakage from the nozzle when the burner is in stand-by and prepurge phase.

The models are fitted with a maximum pressure switch on the oil return circuit, and a minimum oil pressure switch on the oil line from the pump to the nozzle.

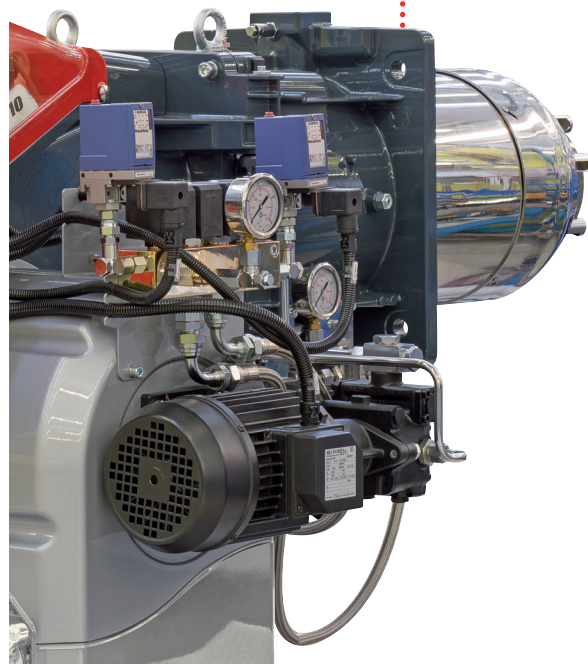

Example of the RLS 310-610 burner hydraulic circuit

P	Pump with filter and pressure regulator
P0 min	Min. oil pressure switch on the delivery circuit
VF	Operating valve
VS	Safety valve on the delivery circuit
MM	Pressure gauge on the delivery circuit
NL	Nozzle pipe
U	Nozzle
MR	Pressure gauge on the return circuit
SM	Servomotor
R0	Pressure regulator on the return circuit
P0 max	Max. oil pressure switch on the return circuit
VR	Safety valve on the return circuit
VR1	Safety valve on the return circuit

### EN 267 > 100 Kg/h RLS 310-410-510-610

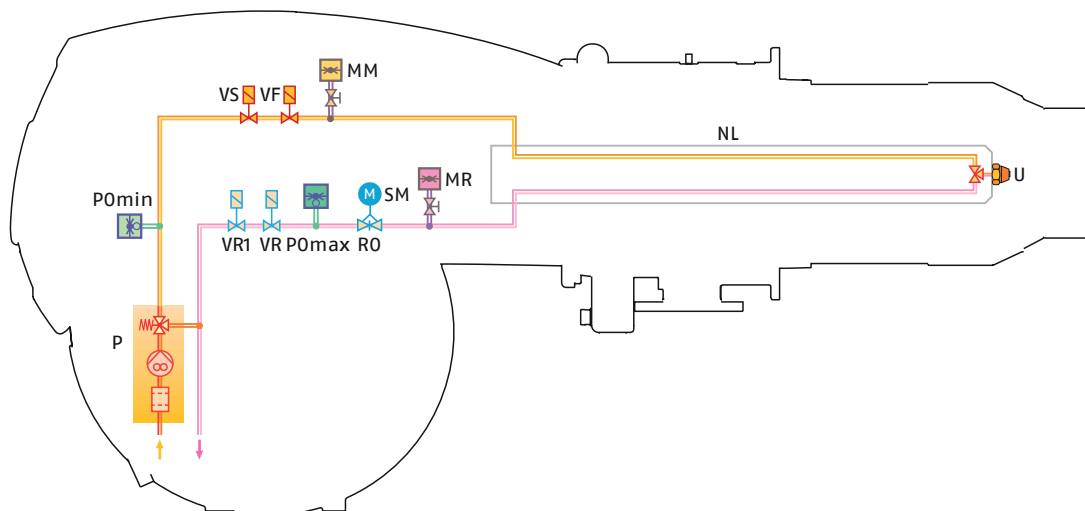



## Selecting the fuel supply lines

The fuel feed must be completed with the safety devices required by the local norms.

The table shows the choice of piping diameter, depending on the difference in height between the burner and the tank and their distance.

### MAXIMUM EQUIVALENT LENGTH FOR THE PIPING L [m]

MODEL	RLS 310-410-510-610			
DIAMETER PIPING	Ø 10 mm	Ø 12 mm	Ø 14 mm	Ø 16 mm
+/- H [m]	L max (m)			
4.0	14	30	55	95
3.5	13	28	52	89
3.0	12	26	48	82
2.5	11	24	44	76
2.0	10	22	41	70
1.5	9	20	37	63
1.0	8	18	33	57
0.5	7	16	29	51
0	6	14	26	44
-0.5	5	12	22	38
-1.0	4	10	18	32
-1.5	3	8	15	25
-2.0	-	6	11	19
-2.5	-	4	7	13
-3.0	-	-	4	7

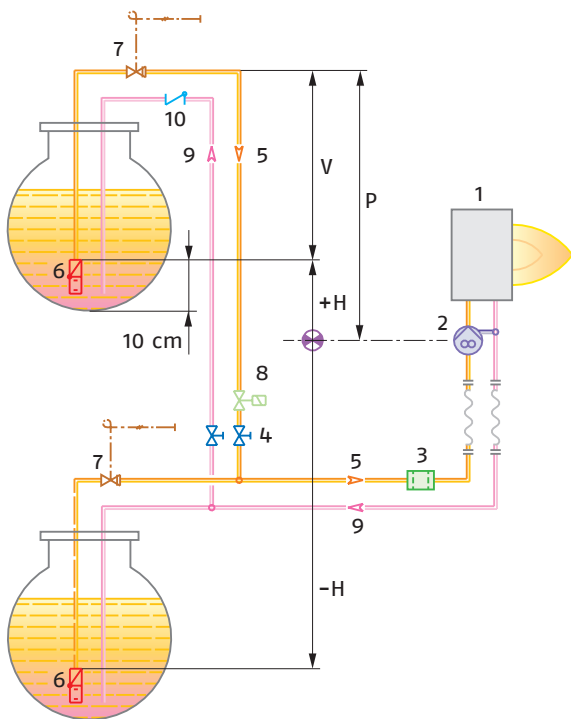

<b>H</b>	Pump/Foot valve height difference
<b>L</b>	Piping length
<b>Ø</b>	Inside pipe diameter
<b>1</b>	Burner
<b>2</b>	Pump
<b>3</b>	Filter
<b>4</b>	Manual on/off valve
<b>5</b>	Suction line
<b>6</b>	Foot valve
<b>7</b>	Quick closing manual valve with remote control (Italy only)
<b>8</b>	On/off solenoid valve (Italy only). See electrical layout. Connections to be carried out by the installer (SV).
<b>9</b>	Return line
<b>10</b>	Check valve (only Italy)

With ring distribution oil systems, the feasible drawings and dimensioning are the responsibility of specialised engineering studios, who must check compatibility with the requirements and features of each single installation.

## Ventilation

The ventilation unit comes with a sound proofing system.

All the burners are fitted with fans, which give excellent performance and are fitted in line with the combustion head. The air flow and sound-deadening materials used in the construction are designed to reduce sound emissions to the minimum and guarantee high levels of performance in terms of output and air pressure.

A high precision servomotor through the main management module installed on each burner, controls the air dampers position constantly.

The RLS models, available on demand are supplied with the "inverter" configuration, which means they are fitted with a device for varying the amount of combustion air through a variable speed action of the fan motor. The burner works at reduced speed, with further benefits in terms of sound emissions, especially during the night when the perception threshold is lower as well decreased power consumption.

### New ventilation structure

A new ventilation structure has been developed in order to reduce the overall dimensions and weight

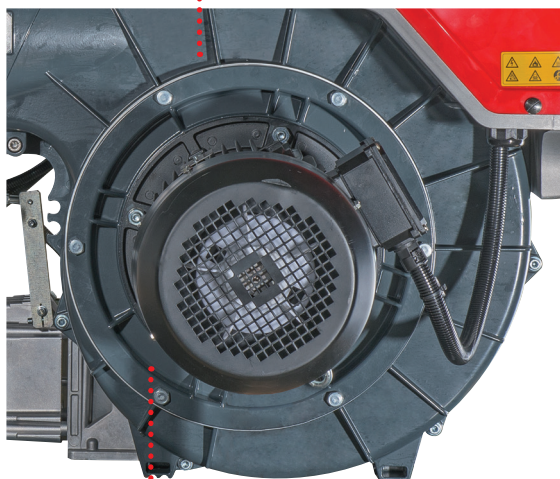

**Simplified Maintenance**  
for motor and fan by direct extraction through opening flange

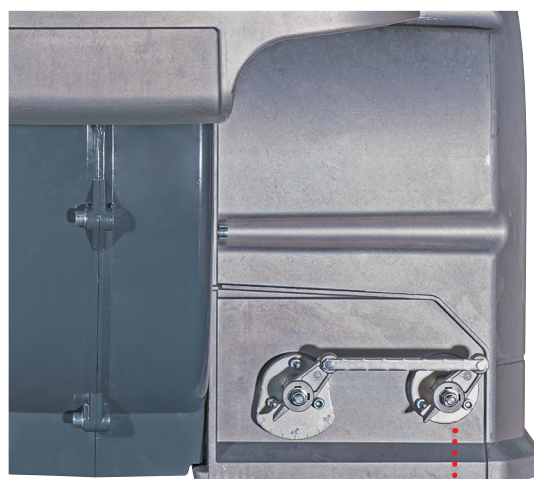

**Air adjusting dampers**  
at air inlet side with ball bearings

## Combustion Head

The innovative combustion head adjustment system ensures perfect movement during modulation as well as reducing noise and pollutants. Simple adjustment of the combustion head allows to adapt internal geometry of the head to the output of the burner.

The same adjustment servomotor for the air damper also varies, depending on the required output, the setting of the combustion head, through a simple lever.

This system guarantees excellent mix on all firing rates range.



Example of a RLS 510/E burner combustion head

## Safe and Green .....

The RLS MX series reduces polluting emissions with its exclusive design which optimises air/fuel mixture.

The gas in the combustion head is distributed through openings which are perpendicular to the air flow; part of the fuel is injected directly into the centre of the flame.

This results in low flame temperature combustion to prevent the formation of NO. Gradual and progressive combustion throughout the flame prevents areas of high oxidation inside the flame.

Emissions are further reduced by the re-circulation of combustion gases due to the high velocity of air leaving the combustion head.

Pollution levels are below even the most severe standard requirements.

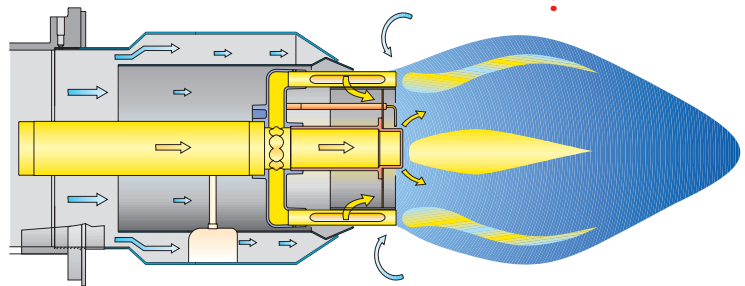

### SUGGESTED COMBUSTION CHAMBER DIMENSIONS

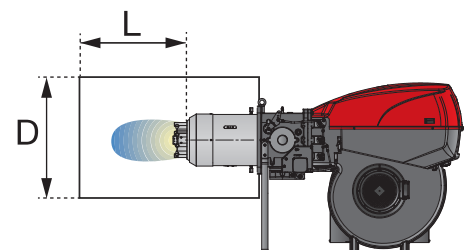
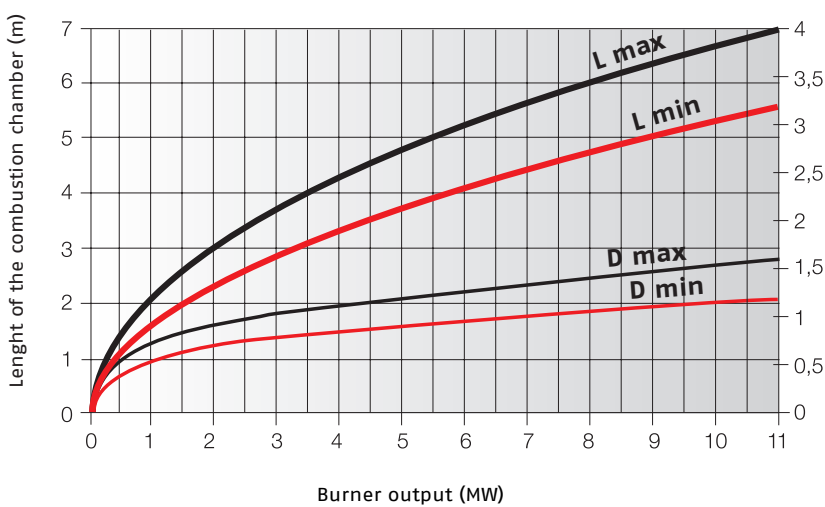

Example:  
 Burner thermal output = 6000 kW;  
 L Combustion Chamber (m) = 4,7 m (medium value);  
 D Combustion Chamber (m) = 1,2 m (medium value)

**NO2 EMISSIONS**

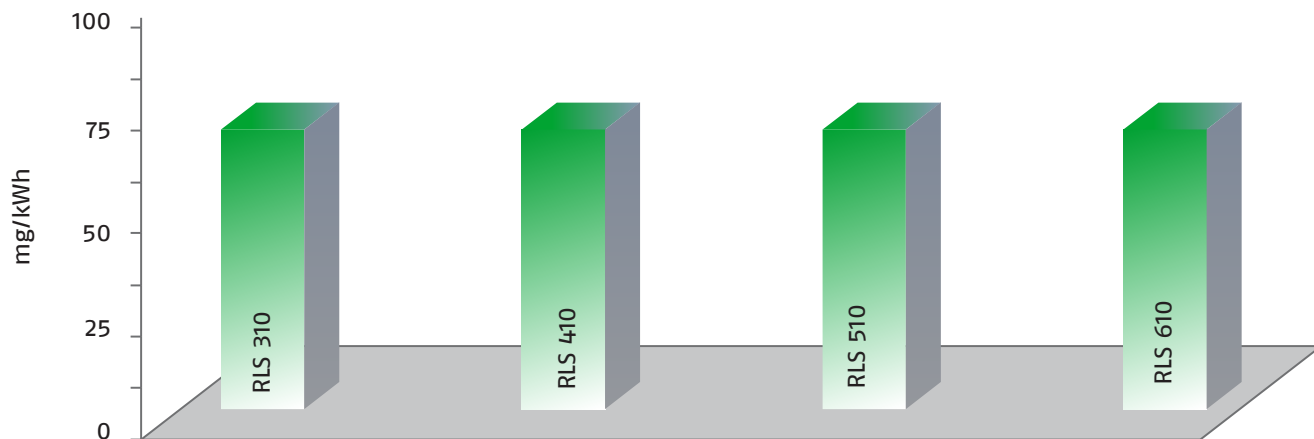

**CO EMISSIONS (gas G20)**

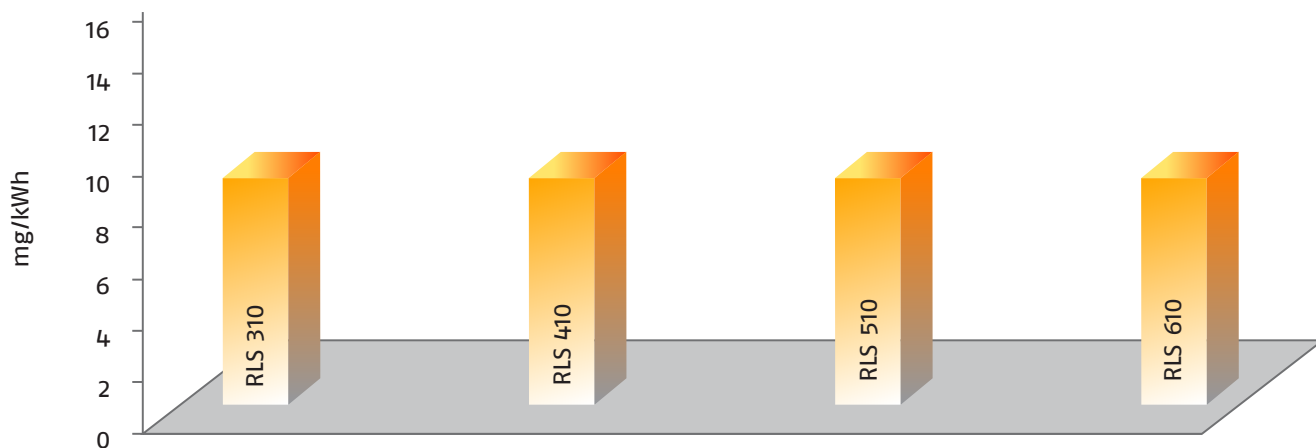

**NOISE EMISSIONS**

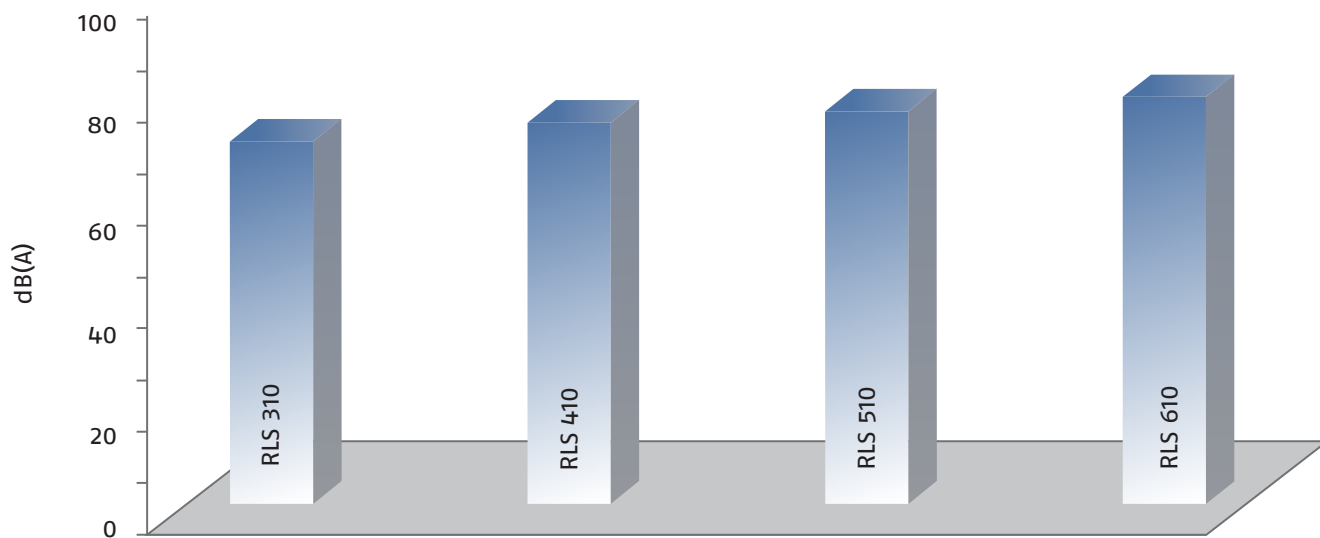

The noise emissions have been measured at the maximum output.

# Operation

## BURNER OPERATION MODE

The RLS 310-410-510-610 series of burners can have "two-stage progressive" or "modulating" operation.



Output regulator



Analog 4-20 mA or 0 - 10V converter for remote modulation

On "two-stage progressive" operation, the burner gradually adapts the output to the requested level, by varying between two pre-set levels (see picture A).

On "modulating" operation, normally required in steam generators, in superheater boilers or diathermic oil burners, a specific regulator and probes are required. These are supplied as accessories that must be ordered separately. The burner can work for long periods at intermediate output levels (see picture B).

### "TWO-STAGE PROGRESSIVE" OPERATION

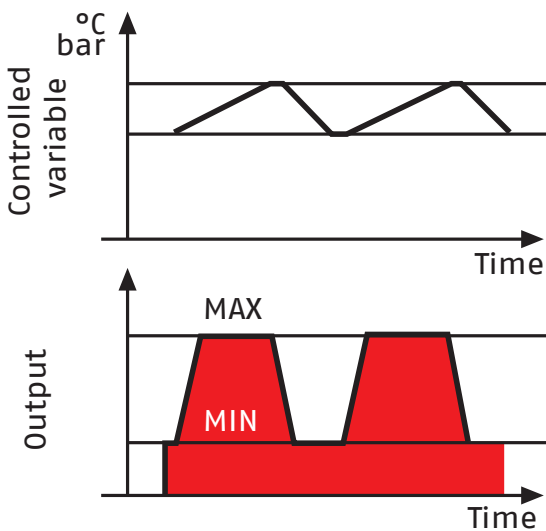

Picture A

### "MODULATING" OPERATION

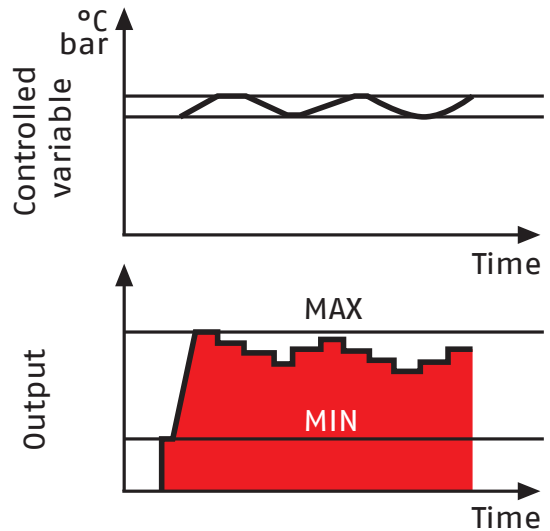

Picture B

**LMV 26 – DIGITAL BURNER MANAGEMENT SYSTEM**

Combustion systems are in continuous evolution and high tech solutions, in particular connected to electronic systems, are today applied in order to obtain better performances and efficiencies.

The Burner is one of the most important component of the combustion system and its evolution is in the direction of the perfect control of operation and more efficiency.

Following this evolution trend RIELLO RLS 310-410-510-610/E MX gas burner series has been upgraded with the introduction of new models with modulating operation obtained by Electronic Cam. The new models are based on the Digital Burner Management Systems RIELLO LMV 26, which is able to manage the air-fuel ratio by independent servomotors in order to obtain a perfect output control and to assure a correct combustion and safe operation on all modulation range. The standard RLS/E burners are equipped with Siemens LMV 26 and, on demand, with Siemens LMV51-52 or Lamtec BT 340 system.

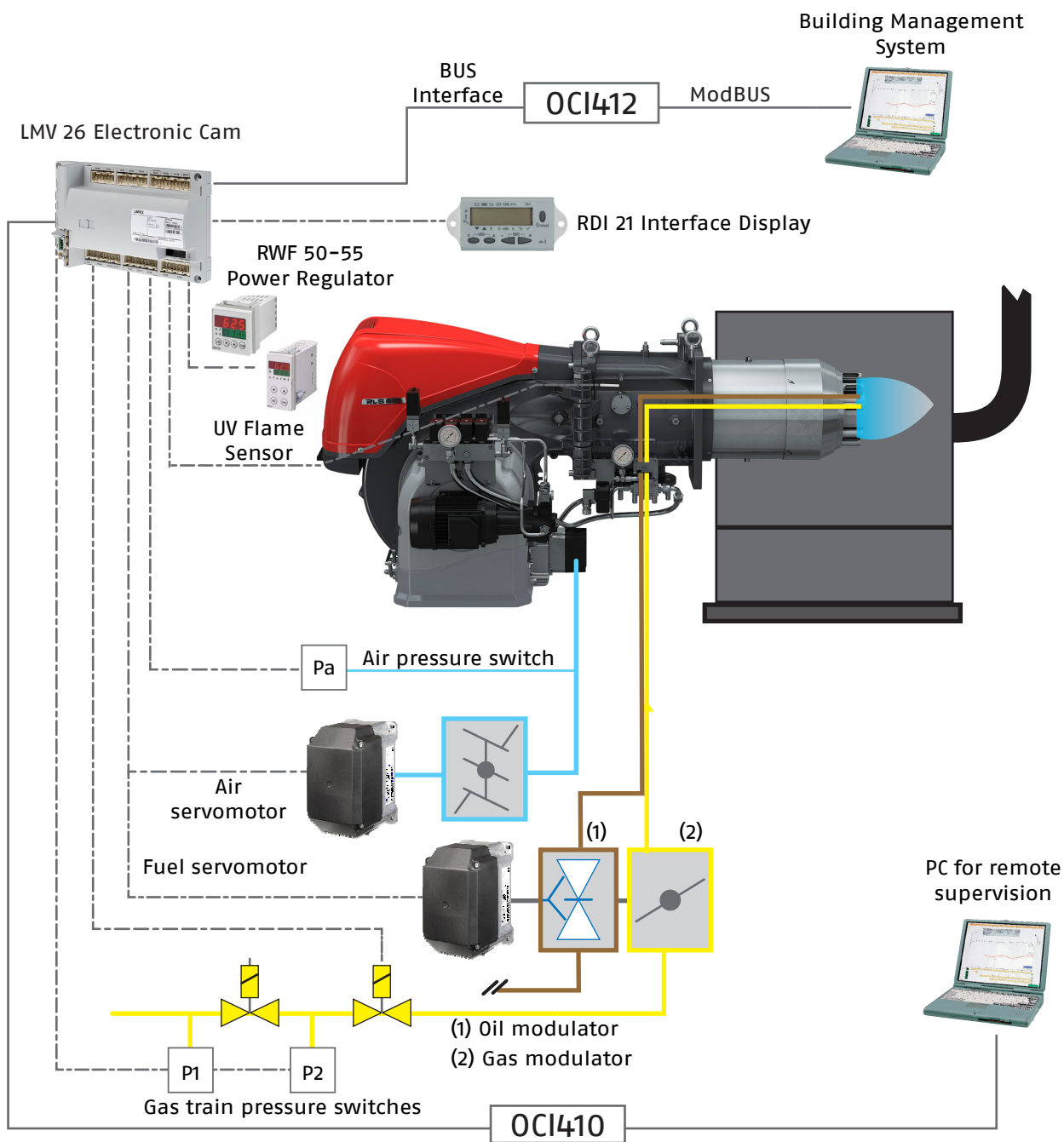

**LMV 26 ELECTRONIC CAM SYSTEM**

Function	LMV 26
Intermittent	●
Two stage progressive operation	●
Modulating operation with the installation of a PID electronic regulator	●
Variable speed drive operation	●
Valve proofing system	●
Air fuel mixing control	●
Independent Ignition Point Position	●
Closed air damper during burner stand-by	●
Password protection levels	●
Burner status display	●
Error message	●
Error history	●
Remote lockout reset	●
Continuous Ventilation	●
Start without pre-purging	●
Remote Connections by external OCI410-412 modules	●
Fuel remote selection	●
External oil safety valve control	●
4/20 mA Remote Analogue Control signal	●
Indication of current burner output DC 0 ... 10 V (alternative to VSD control)	●

**FAN SPEED CONTROL (ON DEMAND)**

The inverter device acts on the electrical supply frequency of the fan motor to adjust the air flow through the motor speed variation.

The main advantages of speed control:

- lower sound emissions
- electric power saving.

The fan motor supplies just the necessary air flow, thus reducing sound emissions and avoiding energy loss due to the air damper regulation mechanism. The inverter technology can save up to 35% of the energy costs. A safety device to verify the correct speed of the motor is mounted on the air suction circuit of the burner.

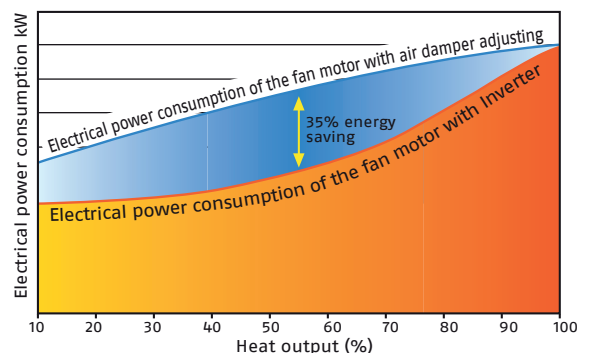

## Overall Dimensions (mm)

BURNERS RLS 310-410-510-610/M MX

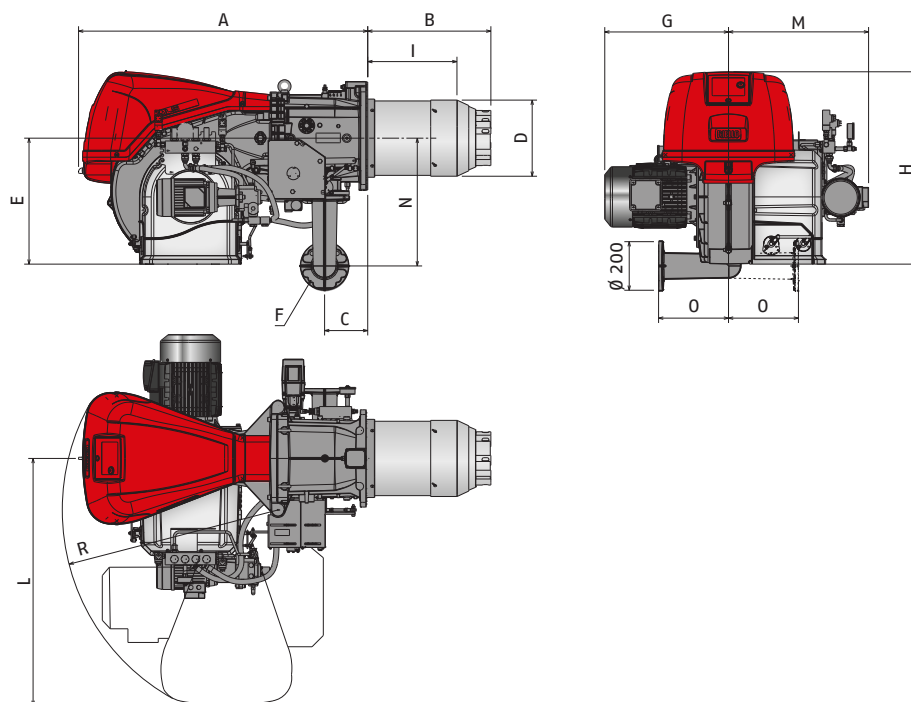

MODEL	A	B	C	D	E	F	G	H	I	L	M	N	O	R
RLS 310/M MX	1190	507	178	313	520	DN65	490	790	340	1015	576	528	290	890
RLS 410/M MX	1190	507	178	313	520	DN65	508	790	340	1015	576	528	290	890
RLS 510/M MX	1190	507	178	313	520	DN65	508	790	340	1015	576	528	290	890
RLS 610/M MX	1190	510	178	334	520	DN65	580	790	360	1015	576	528	290	890

### BURNER - BOILER MOUNTING FLANGE

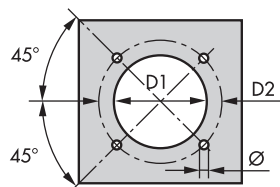

MODEL	D1	D2	Ø
RLS 310/M MX	335	452	M18
RLS 410/M MX	335	452	M18
RLS 510/M MX	335	452	M18
RLS 610/M MX	350	452	M18

### PACKAGING

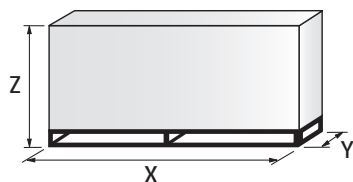

MODEL	X	Y	Z	kg
RLS 310/M MX	2040	1180	1125	300
RLS 410/M MX	2040	1180	1125	300
RLS 510/M MX	2040	1180	1125	300
RLS 610/M MX	2400	1400	1595	320



**BURNERS RLS 310-410-510-610/E MX**

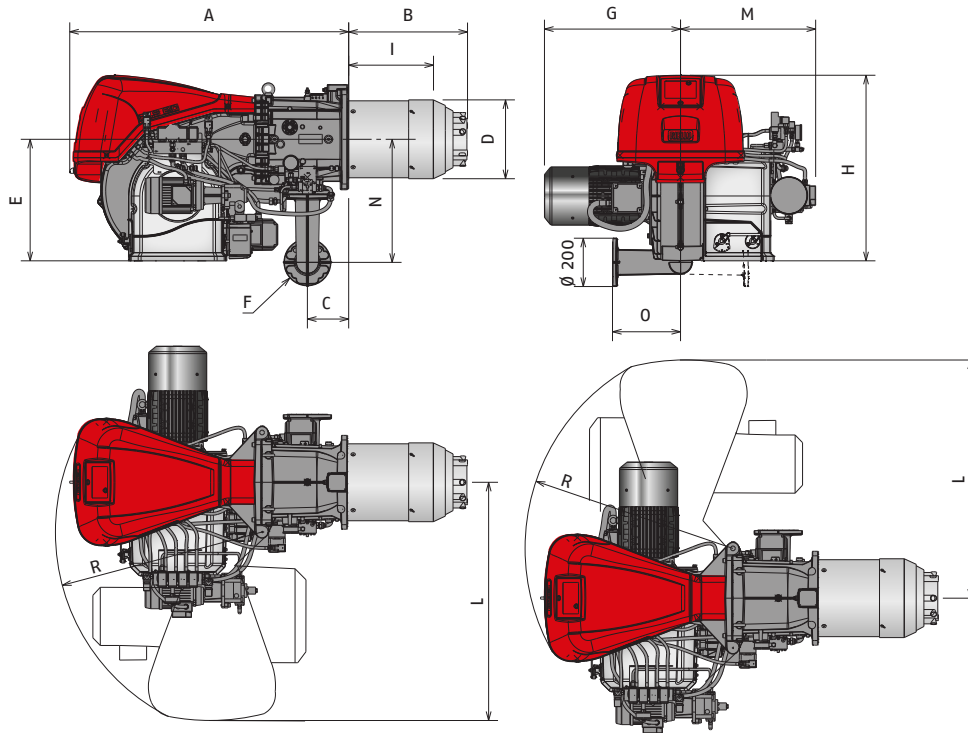

MODEL	A	B	C	D	E	F	G	H	I	L	M	N	O	R
RLS 310/E MX	1190	507	178	313	520	DN65	490	790	340	1015	576	528	290	890
RLS 410/E MX	1190	507	178	313	520	DN65	508	790	340	1015	576	528	290	890
RLS 510/E MX	1190	507	178	313	520	DN65	508	790	340	1015	576	528	290	890
RLS 610/E MX	1190	510	178	334	520	DN65	580	790	360	1015	576	528	290	890

**BURNER - BOILER MOUNTING FLANGE**

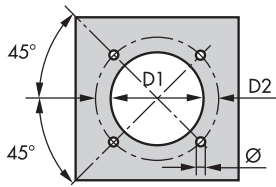

MODEL	D1	D2	Ø
RLS 310/E MX	335	452	M18
RLS 410/E MX	335	452	M18
RLS 510/E MX	335	452	M18
RLS 610/E MX	350	452	M18

**PACKAGING**

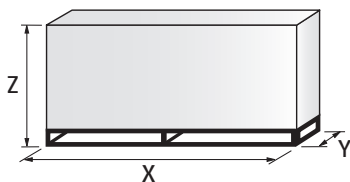

MODEL	X	Y	Z	kg
RLS 310/E MX	2040	1180	1125	300
RLS 410/E MX	2040	1180	1125	300
RLS 510/E MX	2040	1180	1125	300
RLS 610/E MX	2400	1400	1595	320

## Burner accessories

### NOZZLES

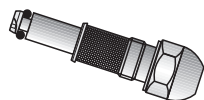

Return nozzles without needle are used on RLS MX burners. The nozzle must be ordered as accessory. The following table shows the features and codes on the basis of the maximum required fuel output.

BURNER	RATED DELIVERY (kg/h)	NOZZLE CODE <sup>(1)</sup>	NOZZLE CODE <sup>(2)</sup>
RLS 310-410/E MX	150	3009314	3045479
RLS 310-410/E MX	175	3009316	3045481
RLS 310-410/E MX	200	3009318	3045483
RLS 310-410/E MX	225	3009320	3045485
RLS 310-410-510/E MX	250	3009322	3045487
RLS 310-410-510/E MX	275	3009324	3045489
RLS 310-410-510-610/E MX	300	3009326	3045491
RLS 310-410-510-610/E MX	325	3009328	3045493
RLS 310-410-510-610/E MX	350	3009330	3045495
RLS 310-410-510-610/E MX	375	3009332	3045497
RLS 310-410-510-610/E MX	400	3009334	3045499
RLS 310-410-510-610/E MX	425	3009336	3045500
RLS 510-610/E MX	450	3009338	3045501
RLS 610/E MX	475	3009340	-
RLS 610/E MX	500	3009342	3045503
RLS 610/E MX	525	3009344	-
RLS 610/E MX	550	3009346	3045505
RLS 610/E MX	575	3009348	-
RLS 610/E MX	600	3009350	3045507

<sup>(1)</sup> Nozzle Bergonzo type B5 45° SA

<sup>(2)</sup> Nozzle Fluidics type N2 45°

For more information please contact Riello Burners Commercial and Technical Department, our Application Engineers will be pleased to help you.

## ACCESSORIES FOR MODULATING OPERATION

### POWER CONTROLLER



To obtain modulating operation, the RS/M BLU series of burners requires a regulator with three point outlet controls. The following table lists the accessories for modulating operation with their application range.

BURNER	TYPE	CODE
RLS 310-410-510-610/M	RWF 50.2 - Basic version with 3 position output	20073595
RLS 310-410-510-610/E	RWF 50.2 - Basic version with 3 position output	20085417
All models	RWF 55.5 - Complete with RS-485 interface	20074441
	RWF 55.6 - Complete with RS-485/PROFIBUS interface	20074442

### PROBE



The relative temperature or pressure probes fitted to the power controller must be chosen on the basis of the application.

BURNER	TYPE	RANGE (°C) (bar)	CODE
All models	Temperature PT 100	-100 ÷ 500°C	3010110
	Pressure 4 ÷ 20 mA	0 ÷ 2,5 bar	3010213
	Pressure 4 ÷ 20 mA	0 ÷ 16 bar	3010214

### ANALOG CONTROL SIGNAL CONVERTER



BURNER	TYPE (INPUT SIGNAL)	CODE
RLS 310-410-510-610/M	0/2 - 10 V (impedance 200 KΩ) 0/4 - 20 mA (impedance 250 Ω)	20074479

### POTENTIOMETER



BURNER	CODE
RLS 310-410-510-610/M	20096322

It is necessary for analogic control signal converter operation.

**PC INTERFACE KIT**



To connect the control panel to a personal computer for the transmission of operation, fault signals and detailed service information, an interface adapter with PC software are available.

BURNER	CODE
RLS 310-410-510-610/E (ACS410 + OCI410.30) - Service level	3010436

**OCI412 INTERFACE KIT**



Interface kit between the REC 27.1 and a Modbus system, such as a building automation and control system (BACS). The Modbus interface is based on the RS-485 standard.

BURNER	CODE
RLS 310-410-510-610/E	3010437

**SOUND PROOFING BOX**

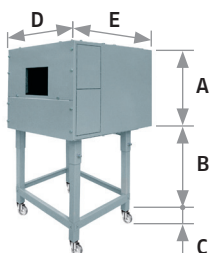

If noise emission needs reducing even further, sound-proofing boxes are available. In case of generator heights, where a lower dimension "B" is required, ask for the Box Support Kit code 20065135. The useful dimensions are 40 mm less than the total dimensions indicated in the table (A, D, E). Not suitable for outdoor use.

BURNER	BOX TYPE	A (mm)	B (mm) min. - max.	C (mm)	D (mm)	E (mm)	[dB(A)](*)	CODE
RLS 310-410	C7	1255	160 - 980	110	1140	1345	10	3010376
RLS 510-610	C7 plus	1255	160 - 980	110	1240	1345	10	20085111

(\*) Average noise reduction according to EN 15036-1 standard

**SPACER KIT**

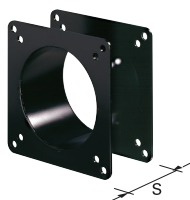

If burner head penetration into the combustion chamber needs reducing, varying thickness spacers are available, as given in the following table:

BURNER	SPACER THICKNESS S (mm)	CODE
All models	180	20008903

**CONTINUOUS VENTILATION KIT**



If the burner requires continuous ventilation in the stages without flame, a special kit is available as given in the following table:

BURNER	CODE
RLS 310-410-510-610/M	20074542
RLS 310-410-510-610/E	20077810

**CLEAN CONTACTS KIT**

<b>BURNER</b>	<b>CODE</b>
RLS 310-410-510-610/E	20096377

**FUEL REMOTE SELECTION KIT**



<b>BURNER</b>	<b>CODE</b>
RLS 310-410-510-610/M	on demand

## Gas train accessories

### STABILISER SPRING





To vary the pressure range of the gas train stabilisers, accessory springs are available. The following table shows these accessories with their application range. Please refer to the technical manual for the correct choice of spring.

GAS TRAIN	SPRING COLOUR	SPRING Pressure range mbar	SPRING CODE
MBC 1900/1 - 3100/1 MBC 5000/1	White	4 - 20	3010381
	Red	20 - 40	3010382
	Black	40 - 80	3010383
	Green	80 - 150	3010384
CB 512/1	Red	25 - 55	3010131
	Black	60 - 110	3010157
	Pink	90 - 150	3090486
CB 520/1 - 525/1	Red	25 - 55	3010132
	Black	60 - 110	3010158
	Pink	100 - 150	3090487
CB 5065/1 - 5080/1	Red	25 - 55	3010133
	Black	60 - 110	3010135
	Pink	100 - 150	3090456
	Grey	140 - 200	3090992
CB 50100/1	Red	25 - 55	3010134
	Black	60 - 110	3010136
	Pink	100 - 150	3090489
	Grey	140 - 200	3092174
	Red	25 - 55	3010315
CB 50125/1	Yellow	30 - 70	3010316
	Black	60 - 110	3010317
	Pink	100 - 150	3010318

**ADAPTERS**

In certain cases, an adapter must be fitted between the gas train and the burner, when the diameter of the gas train is different from the set diameter of the burner.

Below are given the available adapters; please see on the Gas Train list the correct adapter codes to select.

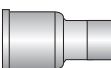
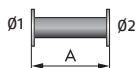
ADAPTER	DIMENSIONS				ADAPTER CODE
	Ø1 DN	Ø2 DN	A mm	B mm	
1" 1/2  2"	-	-	65	-	20064220
2"  2"	-	-	65	-	20042324
DN 80  2" 1/2  2"	-	-	300	-	3000826
	65	80	400	-	3010221
	80	80	400	-	3010222
	100	80	400	-	3010223
	125	80	320	-	3010224

**SEAL CONTROL KIT RLS 310-410-510-610/M**



To test the valve seals on the gas train, a special "seal control kit" is available. The valve seal control device is compulsory (EN 676) on gas trains to burners with a maximum output over 1200 kW. The seal control is type VPS 504.

GAS TRAIN	KIT CODE for 50 Hz operation
MB type	3010123
MCB - CB - DMV type	3010367

**PVP (PRESSURE VALVE PROVING KIT)\* RLS 310-410-510-610/E**

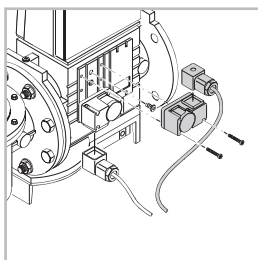

The seal control function is included on Burner Digital Management System, it is only necessary to add the PVP kit on the gas train.

GAS TRAIN	CODE
MB - CB - DMV type	3010344

\* not necessary for those models where is included as a standard.

# Specification

## DESIGNATION OF SERIES

A specific index guides your choice of burner from the various models available in the RS/M C13 series. Below is a clear and detailed specification description of the product.

Series: R									
Fuel: S Natural Gas									
L Light oil									
LS Light oil/Natural Gas									
N Heavy oil									
Size:									
Setting: /1 Single stage					/E Electronic cam				
/B Two stage					/P Proportioning air/gas valve				
/M Modulating-Mechanical cam					/EV Electronic cam predisposed for variable speed (with inverter)				
Emission: ... or CO1					Class 1 EN267 - EN676				
MZ					Class 2 EN267 - EN676				
BLU					Class 3 EN267 - EN676				
MX					Class 2 EN267				
					Class 3 EN676				
Head length: TC standard head									
TL extended head									
Flame control system: FS1 Standard/Intermittent (at least 1 stop every 24 h)									
FS2 Continuous (1 stop every 72 h)									
Electrical supply to the system:									
1/230/50					1/230V/50Hz				
3/230/50					3/230V/50Hz				
3/400/50					3N/400V/50Hz				
3/230-400/50					3/230V/50Hz - 3N/400V/50Hz				
3/220/60					3/220V/60Hz				
3/380/60					3N/380V/60Hz				
3/220-380/60					3/220/60Hz - 3N/380V/60Hz				
Auxiliary voltage: 230/50-60 230V/50-60H									
110/50-60 110V/50-60Hz									
R	LS	510	/M	BLU	TC	FS1	3/230-400/50	230/50-60	
BASIC DESIGNATION									
EXTENDED DESIGNATION									



## STATE OF SUPPLY

Monoblock forced draught dual fuel burners with modulating operation, fully automatic, made up of:

- High performance fan with low sound emissions, forward curve blades
- Air suction circuit lined with sound-proofing material
- Air damper for air setting controlled by a high precision servomotor
- Air pressure switch
- Fan starting motor at 2900 rpm, three-phase 230/400 - 400/690 V with neutral, 50Hz
- Low emission combustion head, that can be set on the basis of required output, fitted with:
  - stainless steel end cone, resistant to corrosion and high temperatures
  - ignition electrodes; ionisation sensor for flame detection (or UV sensor on demand)
  - flame stability disk
- Maximum gas pressure switch, with pressure test point, for halting the burner in the case of over pressure on the fuel supply line
- Burner safety control box for controlling the system safety: for RLS 310-410-510-610/M models.
- LMV26 with AZL Display Interface, for combustion system commissioning and monitoring, for RLS 310-410-510-610/E models
- UV flame sensor
- Star/delta starter for the fan motor (Direct starter fan motor for RLS 30-410 models)
- Main electrical supply terminal board
- Burner on/off switch
- Manual or automatic output increase/decrease switch
- Contacts motor and thermal relay with release button
- Burner failure led signal and lighted release button
- Burner opening hinge
- Lifting rings
- IP 54 electric protection level
- Gears pump for high pressure fuel supply
- Pump starting motor
- Oil safety valves
- Valve unit with double oil safety valve on the output circuit and double safety valve on the return circuit
- Oil/Gas selector
- Flame inspection window

### Standard equipment:

- 1 flange gasket for gas train adaptor
- 1 adaptor for gas train
- 4 screws for fixing the flange
- 1 thermal screen
- 4 screws for fixing the burner flange to the boiler
- 2 flexible pipes for connection to the oil supply network
- 2 nipples for connection to the pump with gaskets
- 8 gas nozzles (only for RLS 310/E)
- Instruction handbook for installation, use and maintenance
- Spare parts catalogue.

### Gas train

Fuel supply line, in the MULTIBLOC configuration (for a diameter of 1-1/2" and 2") or COMPOSED configuration (from a diameter of DN 65 until a diameter of DN 125), fitted with:

- Filter
- Stabiliser
- Minimum gas pressure switch
- Safety valve
- One stage working valve with ignition gas output regulator.

**Conforming to:**

- 2004/108 EC directive (electromagnetic compatibility)
- 2006/95 EC directive (low voltage)
- 2009/142 EC directive (gas)
- 2006/42 EC directive (machine)
- EN 676 (gas burners)
- EN 267 (oil burners).

**Available accessories to be ordered separately:**

- Power controller
- Probe
- Analog control signal converter
- Potentiometer
- Continuous ventilation kit
- PC interface kit
- OCI412 Interface kit
- Sound proofing box
- Spacer kit
- Clean contacts kit
- Fuel remote selection kit
- Adapters
- PVP (Pressure Proving System)
- Seal Control kit
- Stabiliser spring.

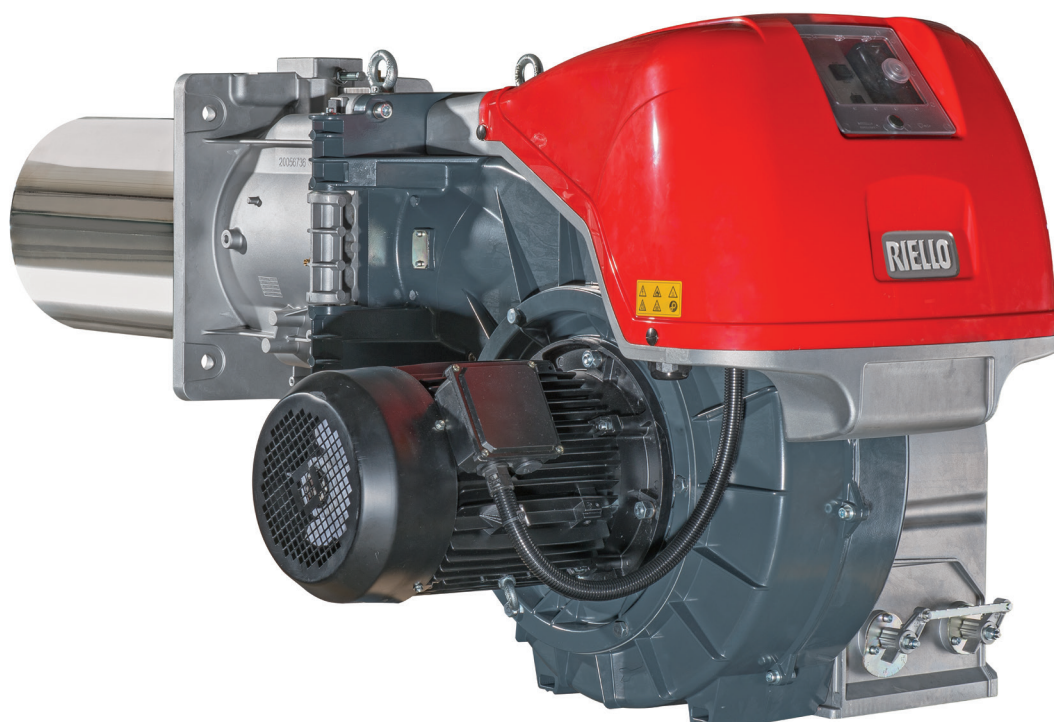





# Riello Burners a world of experience in every burner we sell.

10/2015

P00024UK00



[ 1 ]

Across the world, Riello sets the standard in reliable and high efficiency burner technology.

With burner capacity from 5 kW to 48 MW, Riello gas, oil, dual fuel and Low Nox burners deliver unbeatable performance across the full range of residential and commercial heating applications, as well as in industrial processes.

With headquarter in Legnago, Italy, Riello has been manufacturing premium quality burners for over 90 year. The manufacturing plant is equipped with the most innovative systems of assembling lines and modern manufacturing cells for a quick and flexible response to the market.



[ 2 ]

Besides, the Riello Combustion Research Centre, located in Angiari, Italy, represents one of the most modern facility in Europe and one of the most advanced in the world for the development of the combustion technology.

Today, the company's presence on worldwide markets is distinguished by a well-constructed and efficient sales network, alongside many important Training Centres located in various countries to meet its customers' needs. Riello has 13 operational branches abroad (in Europe, America and Asia), with customers in over 60 countries.

[ 1 ] BURNERS PRODUCTION PLANT  
S. PIETRO, LEGNAGO (VERONA) - ITALIA

[ 2 ] HEADQUARTER BURNERS DIVISION  
S. PIETRO, LEGNAGO (VERONA) - ITALIA

RIELLO S.p.A. - 37045 Legnago (VR) - Italy  
tel. +39 0442 630111 - fax: +39 0442 21980  
[www.riello.com](http://www.riello.com)

Since the Company is constantly engaged in the production improvement, the aesthetic and dimensional features, the technical data, the equipment and the accessories can be changed. This document contains confidential and proprietary information of RIELLO S.p.A. Unless authorised, this information shall not be divulged, nor duplicated in whole or in part.

# RIELLO